

Slide table cylinder

HGS Series

Bore size: $\Phi 6$, $\Phi 8$, $\Phi 10$, $\Phi 12$

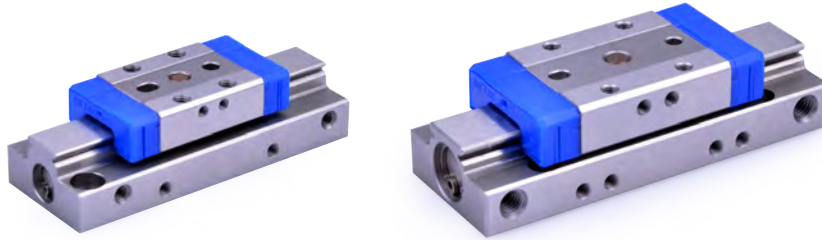

Ordering code

HGS 10×15 S J

① ② ③ ④ ⑤

① Model
HGS: Slide table cylinder

② Bore size
6 8 10 12

⑤ Stroke adjustment device
Blank: Without stroke adjustment device
J: With stroke adjustment device
[Note]



③ Stroke	
Bore size (mm)	Standard stroke (mm)
6	5 10
8	5 10 15 20
10	5 10 15 20
12	5 10 15 20 25

④ Magnet
Blank: Without magnet
S: With magnet



[Note] Stroke adjustment device of $\Phi 10 \setminus \Phi 12$ can be replaced by shock absorber.

Ordering code of accessories

F-HGS 10×15 H

① ② ③ ④

① Model
HGS: Slide table cylinder

② Bore size
6 8 10 12

③ Stroke	
Bore size (mm)	Standard stroke (mm)
6	5 10
8	5 10 15 20
10	5 10 15 20
12	5 10 15 20 25

④ Accessories type
H: Sensor fixed seat package



J: Stroke adjusting screw package



Matching table

		Sensor				
		Stroke (mm)				
Ordering code		5	10	15	20	25
Bore size	6	F-HGS6X5H	F-HGS6X10H			
	8	F-HGS8X5H	F-HGS8X10H	F-HGS8X15H	F-HGS8X20H	
	10	F-HGS10X5H	F-HGS10X10H	F-HGS10X15H	F-HGS10X20H	
	12	F-HGS12X5H		F-HGS12X15H	F-HGS12X20H	F-HGS12X25H

		Stroke adjusting screw				
		Stroke (mm)				
Ordering code		5	10	15	20	25
Bore size	6	F-HGS6X5J	F-HGS6X10J			
	8	F-HGS8X5J	F-HGS8X10J	F-HGS8X15J		
	10	F-HGS10X5J	F-HGS10X10J	F-HGS10X15J		
	12	F-HGS10X10J		F-HGS10X15J		F-HGS10X15J

HGS Series

Bore size: $\Phi 6$, $\Phi 8$, $\Phi 10$, $\Phi 12$

Specification

Bore size(mm)	6	8	10	12
Acting type	Double acting			
Fluid	Air(to be filtered by 40 μ m filter element)			
Operating pressure	36~100psi(0.25~0.7MPa)		29~100psi(0.2~0.7MPa)	
Proof pressure	175psi(1.2MPa)			
Cushion type	Bumper		Bumper or shock absorber	
Temperature	-20~70°C			
Lubrication	Not required			
Speed range	50~500mm/s			
Stroke tolerance	$^{+0.5}_0$			
Sensor switches	DMSH\CMSH \EMSH			
Port size	M3×0.5		M5×0.8	

Production weight table

Unit : g

Model	Body weight	Sensor fixed seat package weight	Stroke adjusting screw package weight		
			Single adjusting screw	Single shock absorber	Other accessories
HGS6X5	116.1	14.25	2.4	-	11.61
HGS10X5	152.3	19.05	2.4	-	11.61
HGS8X5	133.01	14.05	2.4	-	10.34
HGS8X10	167.46	18.54	2.4	-	10.34
HGS8X15	207.07	23.35	2.4	-	10.34
HGS8X20	239.37	28.16	2.4	-	10.34
HGS10X5	194.26	15.91	6.8	16	27.36
HGS10X10	248.98	19.12	6.8	16	26.2
HGS10X15	303.39	24	6.8	16	21.8
HGS10X20	352.05	28.93	6.8	16	21.8
HGS12X5	291.01	21.64	6.8	16	27.36
HGS12X10	318.12	21.64	6.8	16	26.2
HGS12X15	356.79	27.63	6.8	16	21.8
HGS12X20	445.92	33.25	6.8	16	21.8
HGS12X25	491.34	38.87	6.8	16	21.8

Example :

HGS10X15SJ=Body weight+Sensor fixed seat package weight+Single adjusting screw weightX2+Other accessories weight

$$=303.39+24+6.8 \times 2+21.8=362.79(\text{g})$$

Slide table cylinder

HGS Series

Bore size: $\Phi 6$, $\Phi 8$, $\Phi 10$, $\Phi 12$

Table precision

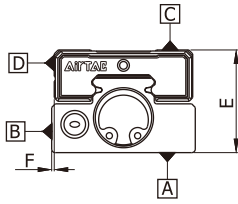

[Unit: mm]

Model		HGS6	HGS8	HGS10	HGS12
Parallelism	C surface to A surface	0.02			
	D surface to B surface	0.02			
Parallelism of walking	C surface to A surface	0.004			
	D surface to B surface	0.004			
Dimensional tolerance of E		±0.05			
Dimensional tolerance of F		±0.05			

Max. allowable torque

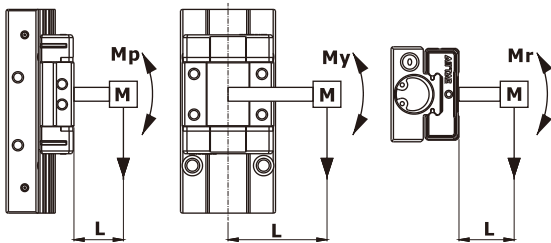

Model	Max. Allowable torque (N.m)		
	Pitch moment M_p	Yaw moment M_y	Roll moment M_r
HGS6X5	0.42	0.42	0.87
HGS6X10			
HGS8X5	0.42	0.42	0.87
HGS8X10			
HGS8X15	1.7	1.7	1.8
HGS8X20			
HGS10X5	1.2	1.4	2.3
HGS10X10			
HGS10X15	2.8	3.1	3.3
HGS10X20			
HGS12X5	2.4	2.9	4.7
HGS12X10			
HGS12X15	6.5	7.7	7.3
HGS12X20			
HGS12X25			

Max. allowable load

[Unit : kg]

Model	HGS6	HGS8	HGS10	HGS12
No stroke adjustment device	0.3	0.3	0.8	1.2
With stroke adjustment device	0.2	0.5	0.8	1.2
With shock absorber	-	-	1.6	2.0

Table deflection

Table deflection due to pitch moment

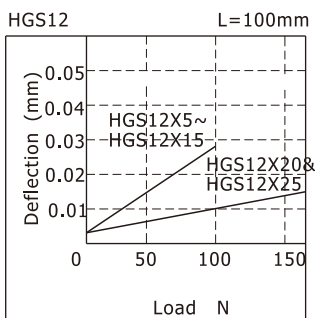
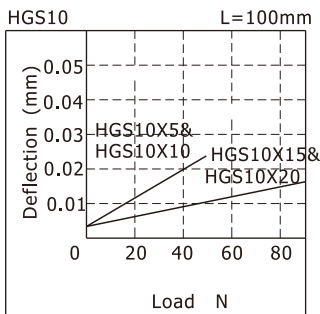
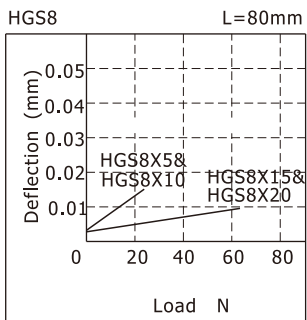
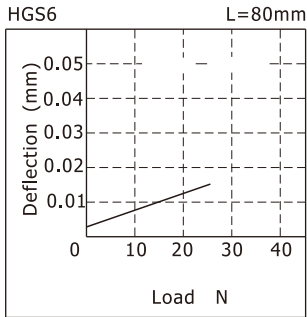
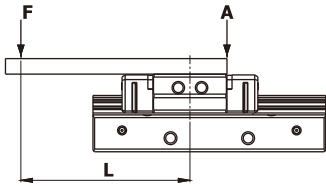

Table deflection due to yaw moment

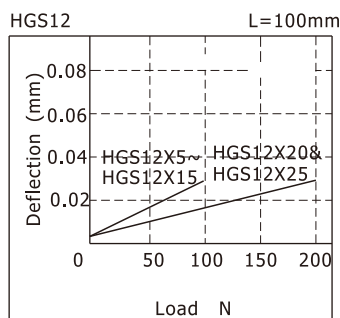
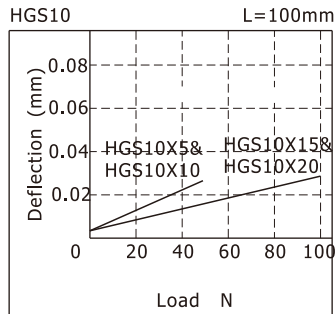
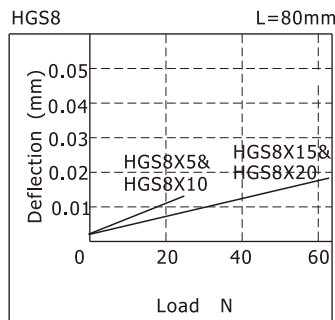
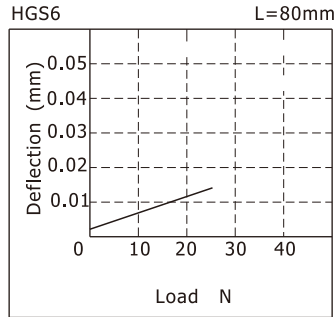
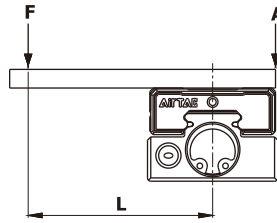
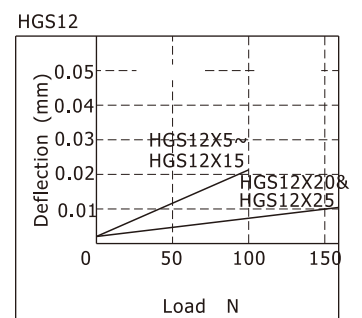
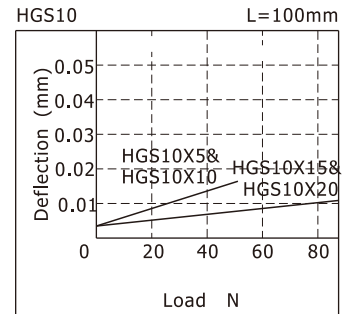
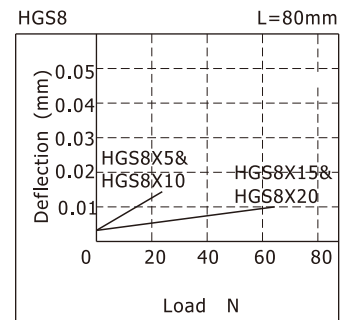
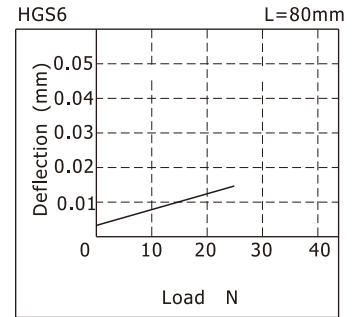
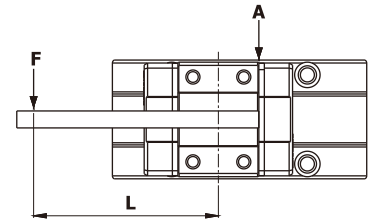

Table deflection due to roll moment



HGS Series

Bore size: $\Phi 6$, $\Phi 8$, $\Phi 10$, $\Phi 12$

Installation and application

1. Cylinder can be mounted from 4 directions
2. When mounting an compact slide cylinder, screws of appropriate length should be used and tightened properly within the maximum tightening torque. If screws are tightened beyond designed limits, malfunction may occur. If they are tightened insufficiently, it may result in sliding or falling off from its position.

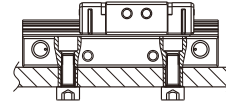
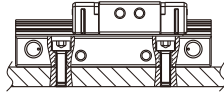

Model	Bolt used	Max. tightening torque (Nm)	Max. screw-in depth(mm)
HGS6	M3×0.5	1.1	4.3
HGS8	M3×0.5	1.1	6.3
HGS10	M3×0.5	1.1	6
HGS12	M3×0.5	1.1	4.8
	M4×0.7	2.5	4.8

Note: M3X0.5 bolt is used for HGS12X5/10.

Model	Bolt used	Max. tightening torque (Nm)	Max. screw-in depth(mm)
HGS6	M4×0.7	2.5	4.3
HGS8	M4×0.7	2.5	6.3
HGS10	M4×0.7	2.5	6
HGS12	M4×0.7	2.5	6.8
	M5×0.8	5.1	6.8

Note: M4X0.7 bolt is used for HGS12X5/10.

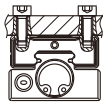

Model	Bolt used	Max. tightening torque (Nm)	Max. screw-in depth(mm)
HGS6	M3×0.5	1.1	3
HGS8	M3×0.5	1.1	3
HGS10	M3×0.5	1.1	3
HGS12	M3×0.5	1.1	4

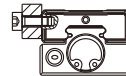

Model	Bolt used	Max. tightening torque (Nm)	Max. screw-in depth(mm)
HGS6	M2×0.4	0.26	4
HGS8	M2×0.4	0.26	4
HGS10	M3×0.5	1.1	3
HGS12	M3×0.5	1.1	4

Installation of Accessories

Locking torque shown in the following table is recommended to tighten the bolts, if bolts are tightened beyond designed limits, malfunction may occur; If they are tightened insufficiently, it may result in sliding or falling off from its position.

Stroke adjustable device

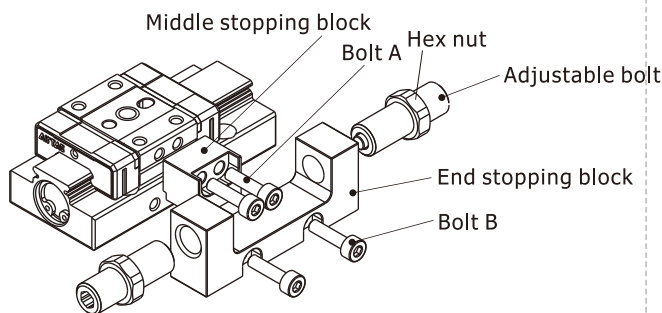

Model	Bolt A used	Max locking torque(N.m)	Bolt B used	Max locking torque(N.m)
HGS6	M2X0.4X10L	0.26	M2.5X0.45X10L	0.36
HGS8	M2X0.4X10L	0.26	M3X0.5X10L	1.1
HGS10	M3X0.5X12L	1.1	M3X0.5X12L	1.1
HGS12	M3X0.5X12L	1.1	M3X0.5X12L	1.1

Sensor Seat

Port-adapter must be assembled correctly, leaks may happen if it is missing.

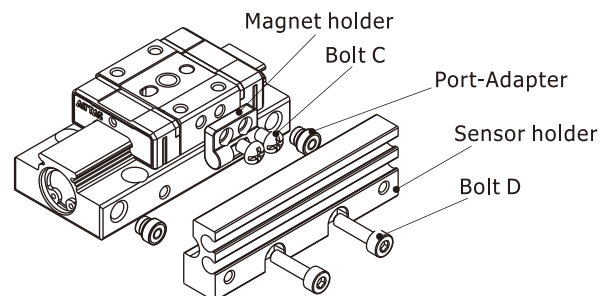

Model	Bolt C used	Max locking torque(N.m)	Bolt D used	Max locking torque(N.m)
HGS6	M2X0.4X6L	0.26	M2.5X0.45X10L	0.36
HGS8	M2X0.4X6L	0.26	M3X0.5X10L	1.1
HGS10	M3X0.5X4L	1.1	M3X0.5X10L	1.1
HGS12	M3X0.5X4L	1.1	M3X0.5X10L	1.1

Sensor seat can be installed on both sides of cylinder while stroke adjustment device can only be installed on the side with no ports.

About shock absorber

1. Shock absorbers are expendable. Promptly replace them when energy absorbing capacity decreases.
2. Never turn or adjust the screws on bottom of the shock absorber body. The screws are not for adjusting. Otherwise would cause oil leakage.
3. Follow the table for tightening torque of shock absorber to lock nuts.

Shock absorber lock nut

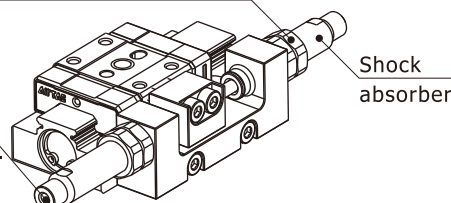

The screws are not adjustable otherwise would cause oil leakage.

Model	Shock absorber	Tightening torque
HGS6	Without shock absorber	
HGS8		
HGS10	ACA0806-1N	1.67(N.m)
HGS12	ACA0806-1N	1.67(N.m)

Slide table cylinder

HGS Series

Bore size: $\Phi 6, \Phi 8, \Phi 10, \Phi 12$

Inner structure

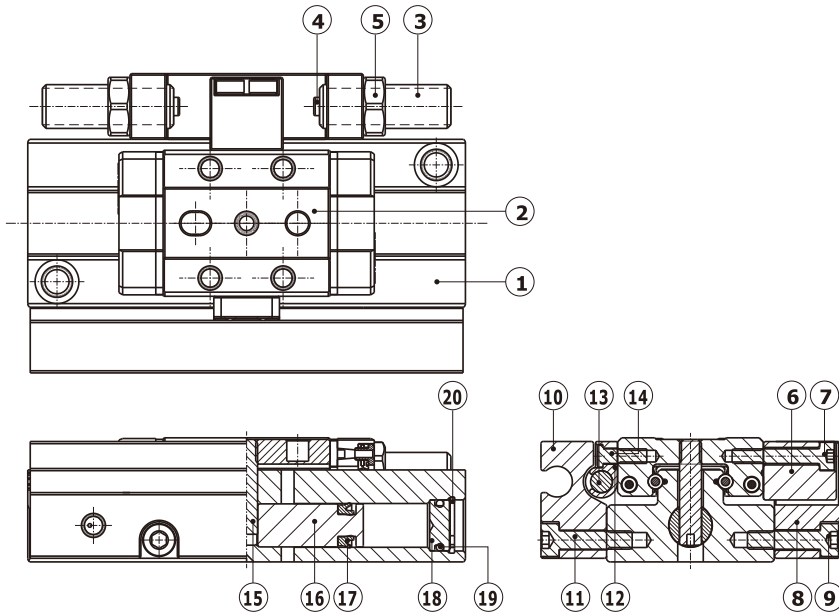

NO.	Item
1	Body
2	Slide table
3	Adjustable screw
4	Bumper
5	Hex nut
6	Middle stopping block
7	Hexagon socket head screws
8	End stopping block
9	Hexagon socket head screws
10	Sensor fixed rail
11	Hexagon socket head screws
12	Magnet holder
13	Magnet
14	Screw
15	Pin
16	Piston
17	Piston packing
18	End cover
19	O ring
20	C clip

Dimensions(HGS6)

HGS6X5

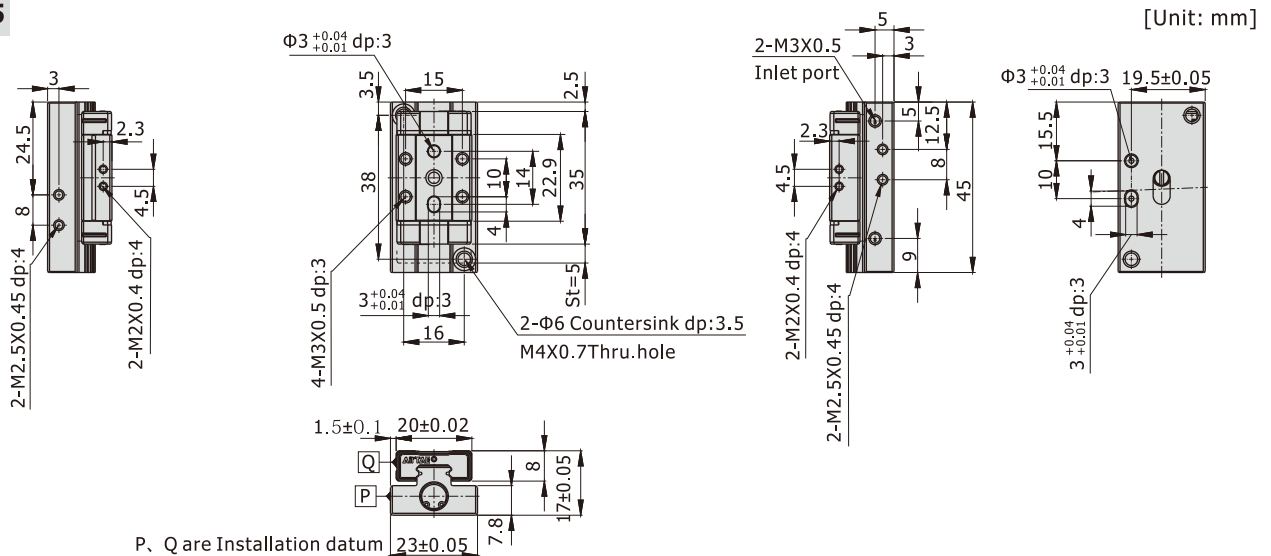

HGS6X5S

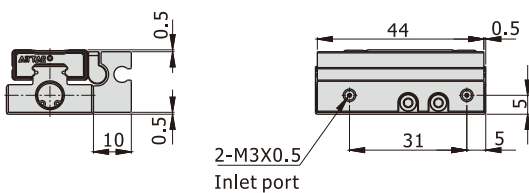

HGS6X5J Adjustable range :5mm

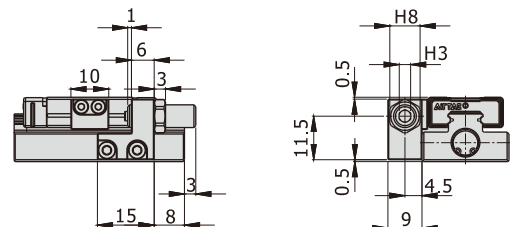

Slide table cylinder

HGS Series

Bore size: $\Phi 6$, $\Phi 8$, $\Phi 10$, $\Phi 12$

HGS6X10

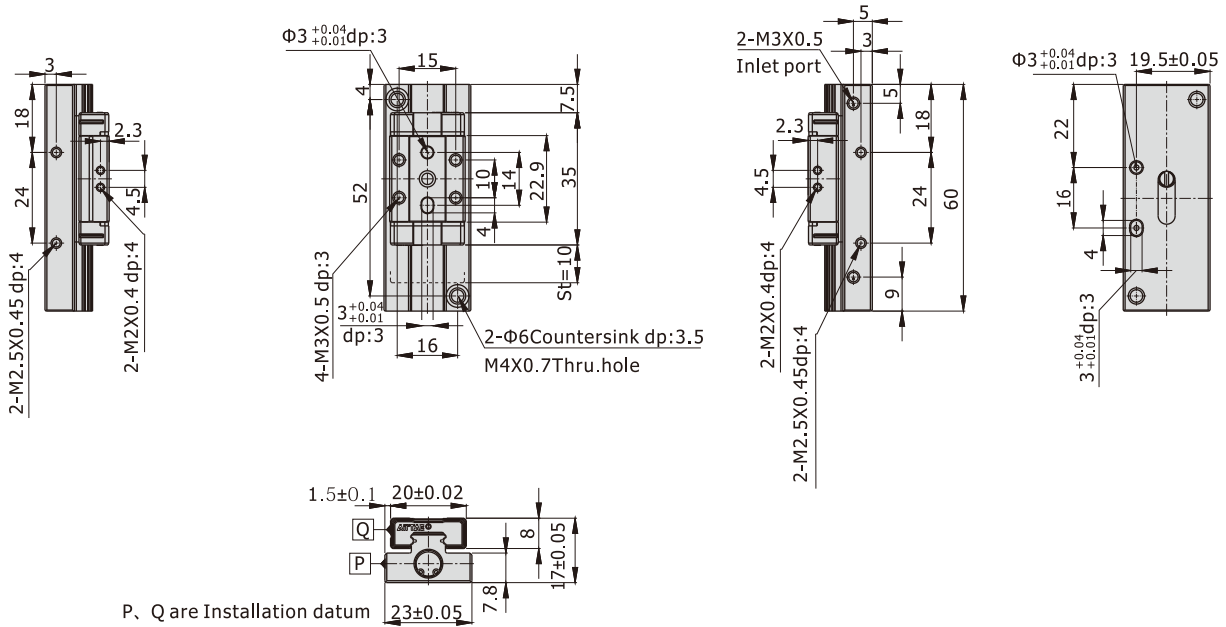

HGS6X10S

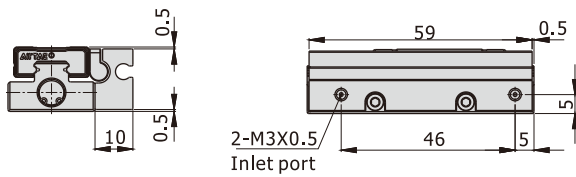

HGS6X10J Adjustable range :5mm of each sides.

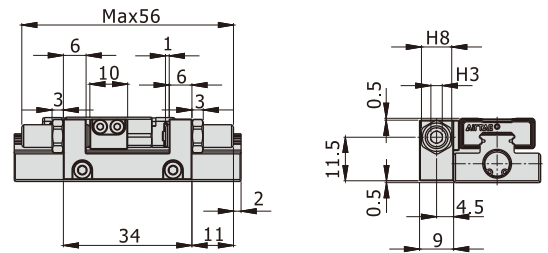

Slide table cylinder

HGS Series

Bore size: $\Phi 6$, $\Phi 8$, $\Phi 10$, $\Phi 12$

Dimensions(HGS8)

HGS8X5

[Unit: mm]

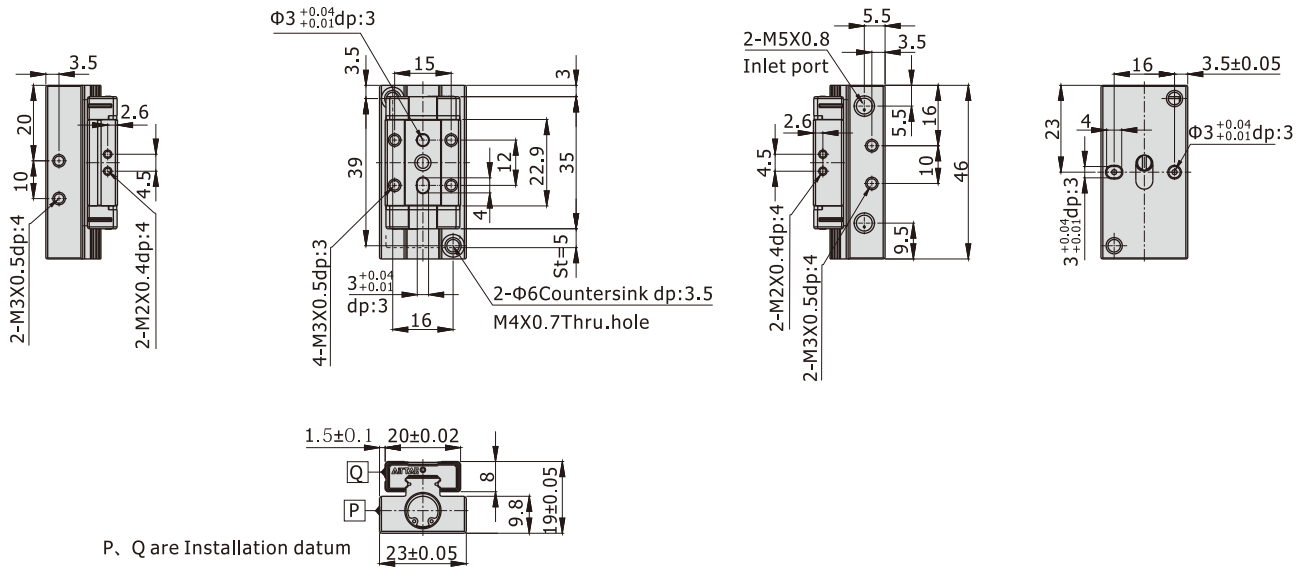

HGS8X5S

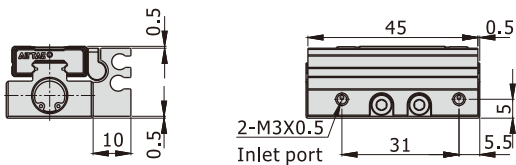

HGS8X5J Adjustable range :5mm

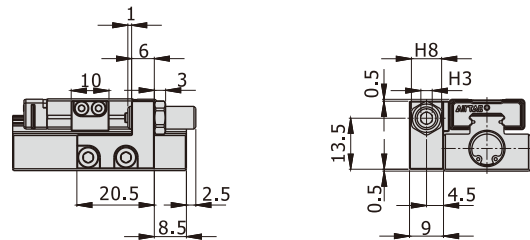

Slide table cylinder

HGS Series

Bore size: $\Phi 6$, $\Phi 8$, $\Phi 10$, $\Phi 12$

HGS8X10

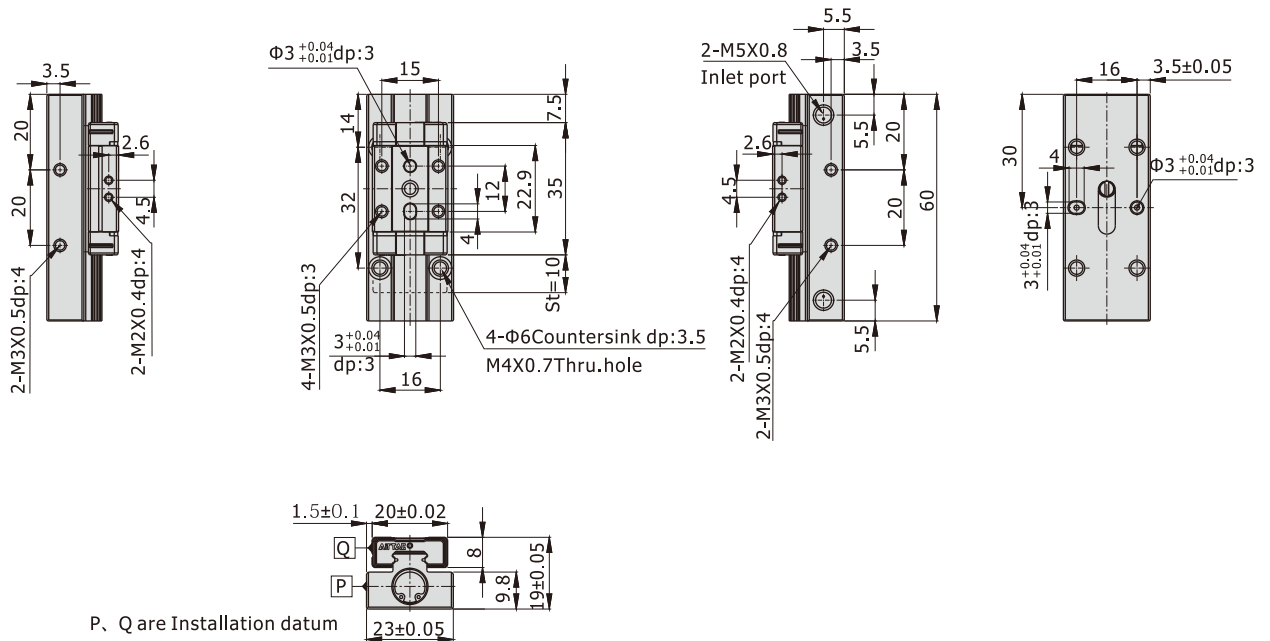

HGS8X10S

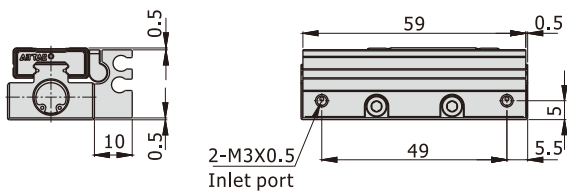

HGS8X10J Adjustable range :5mm of each sides.

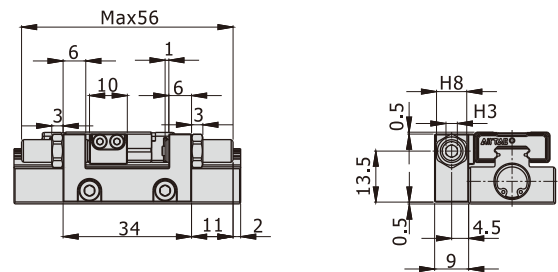

Slide table cylinder

HGS Series

Bore size: $\Phi 6$, $\Phi 8$, $\Phi 10$, $\Phi 12$

HGS8X15

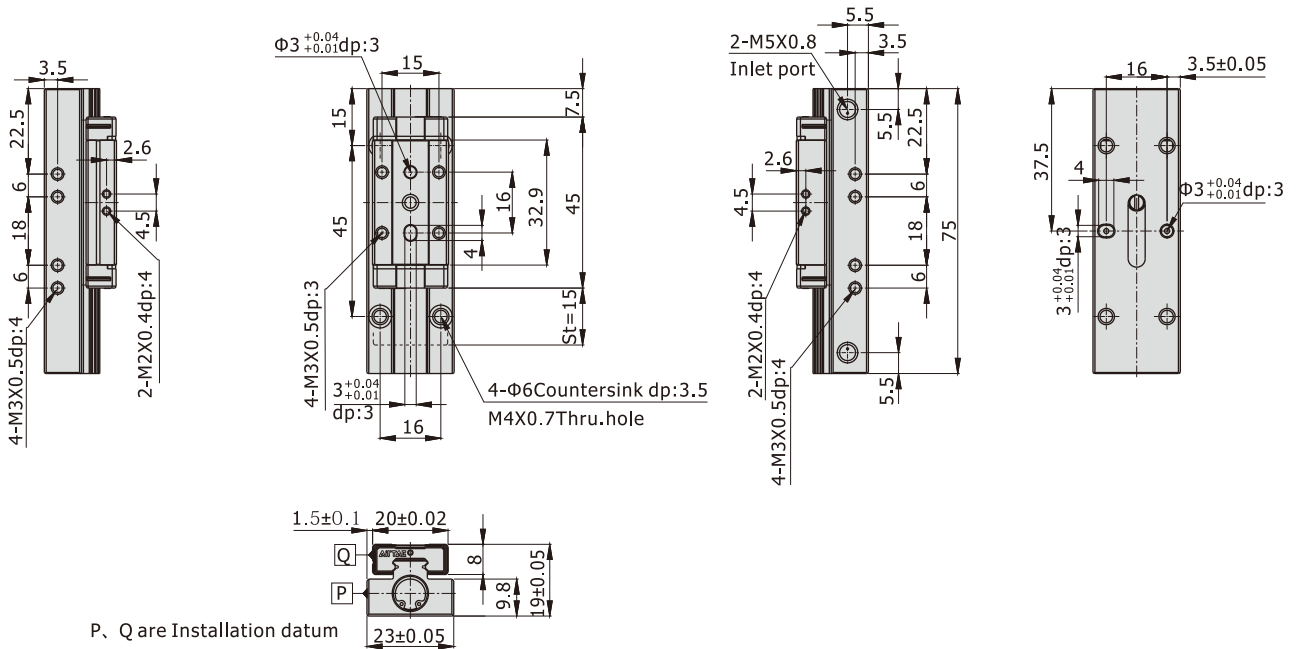

HGS8X15S

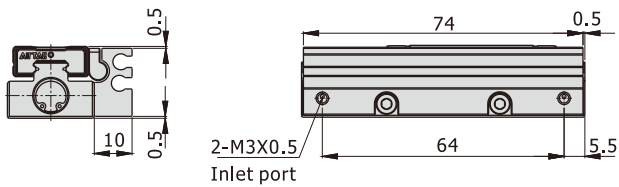

HGS8X15J Adjustable range :5mm of each sides.

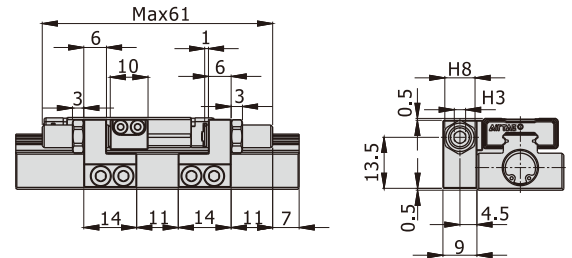

Slide table cylinder

HGS Series

Bore size: $\Phi 6$, $\Phi 8$, $\Phi 10$, $\Phi 12$

HGS8X20

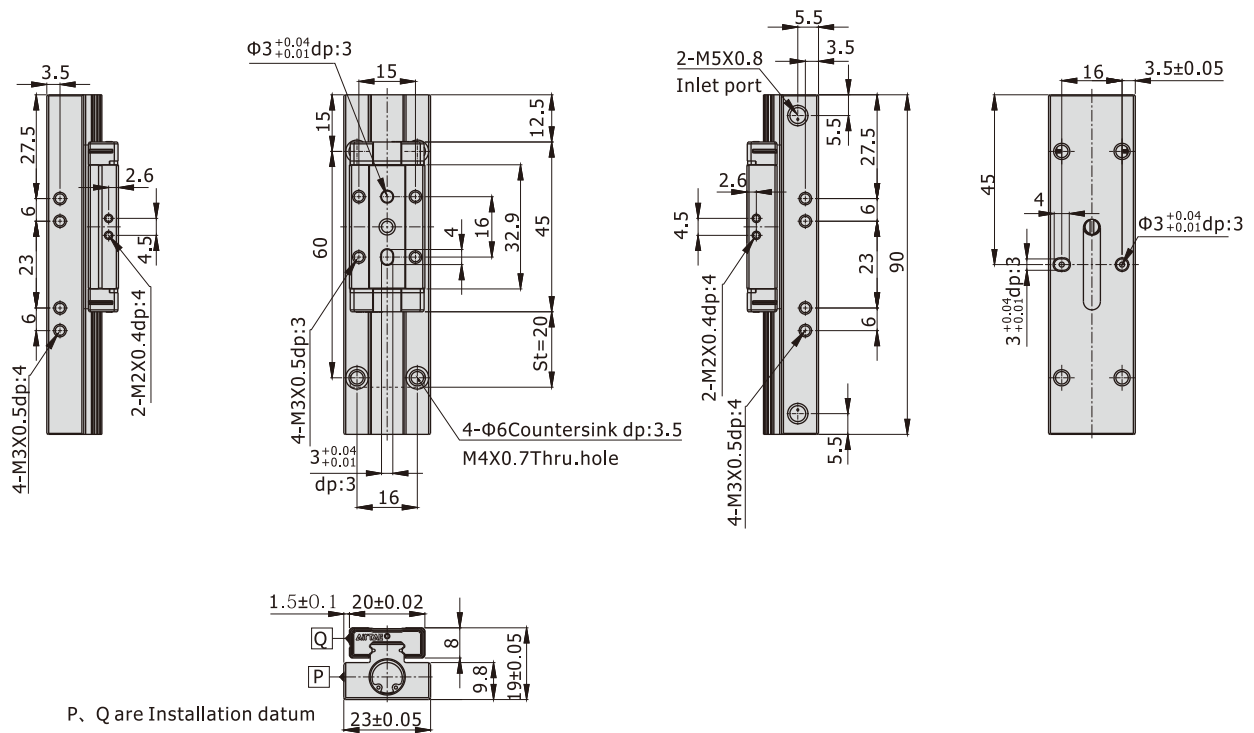

HGS8X20S

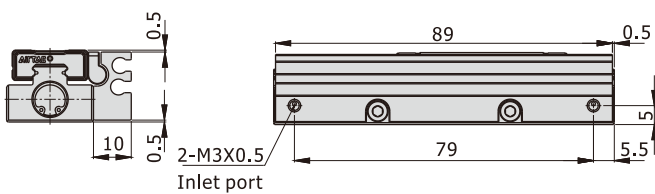

HGS8X20J Adjustable range :5mm of each sides.

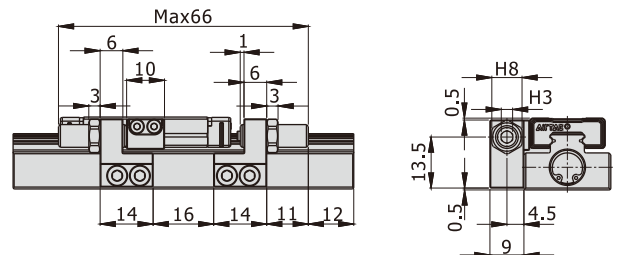

Slide table cylinder

HGS Series

Bore size: $\Phi 6$, $\Phi 8$, $\Phi 10$, $\Phi 12$

Dimensions(HGS10)

HGS10X5

[Unit: mm]

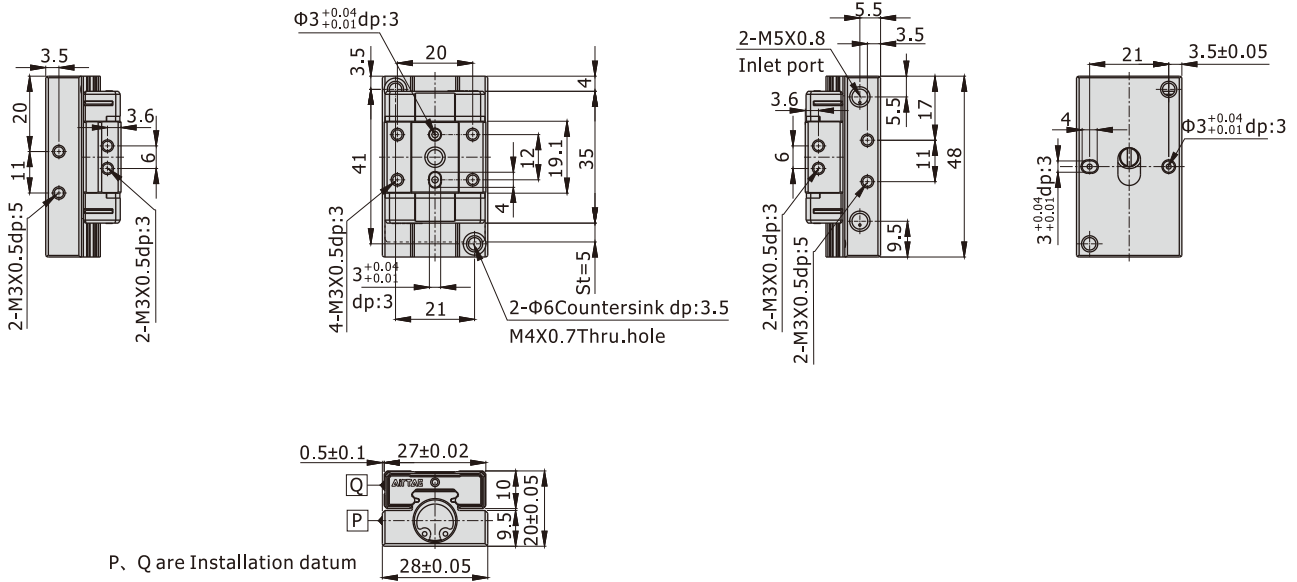

HGS10X5S

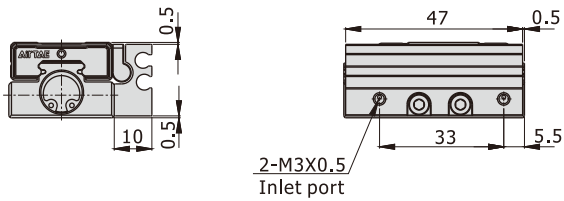

HGS10X5J Adjustable range :5mm

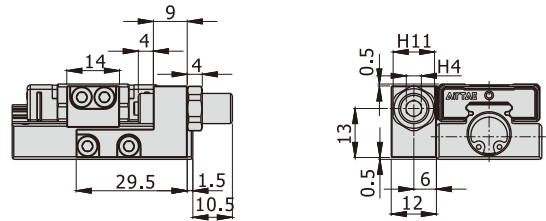

Slide table cylinder

HGS Series

Bore size: $\Phi 6$, $\Phi 8$, $\Phi 10$, $\Phi 12$

HGS10X10

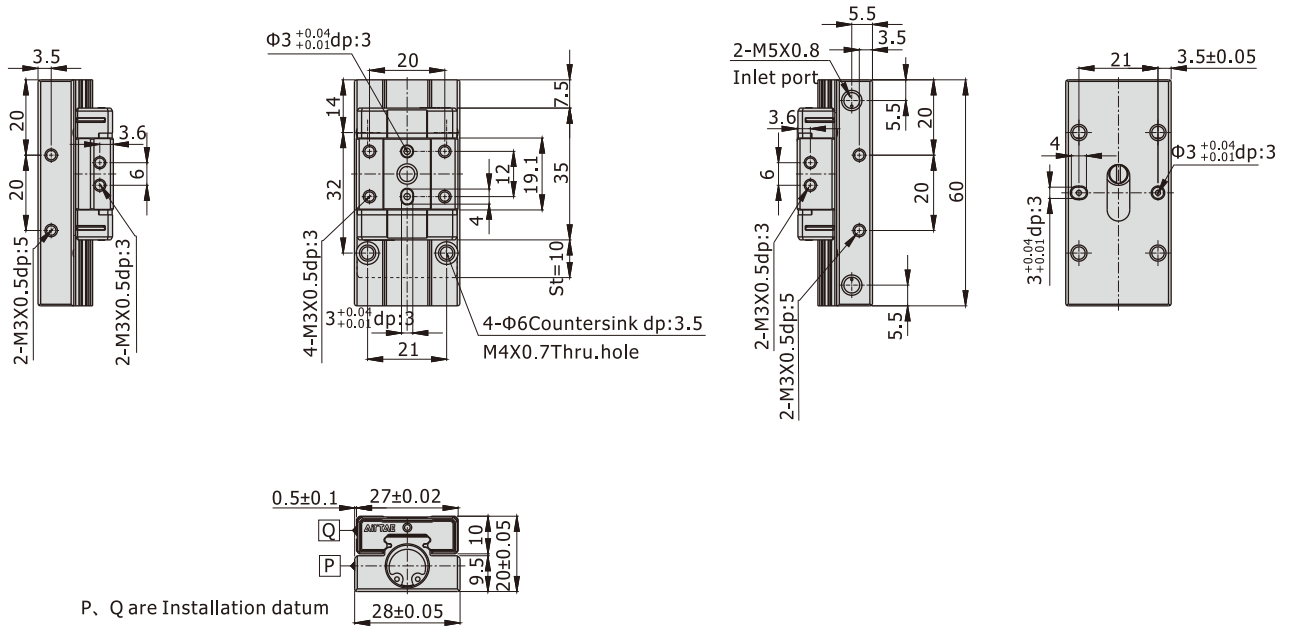

HGS10X10S

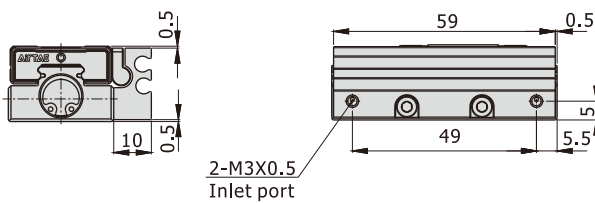

HGS10X10J Adjustable range :5mm of each sides.

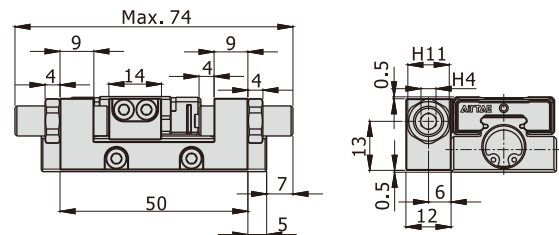

Slide table cylinder

HGS Series

Bore size: $\Phi 6$, $\Phi 8$, $\Phi 10$, $\Phi 12$

HGS10X15

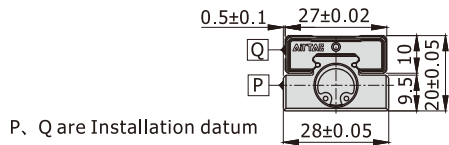
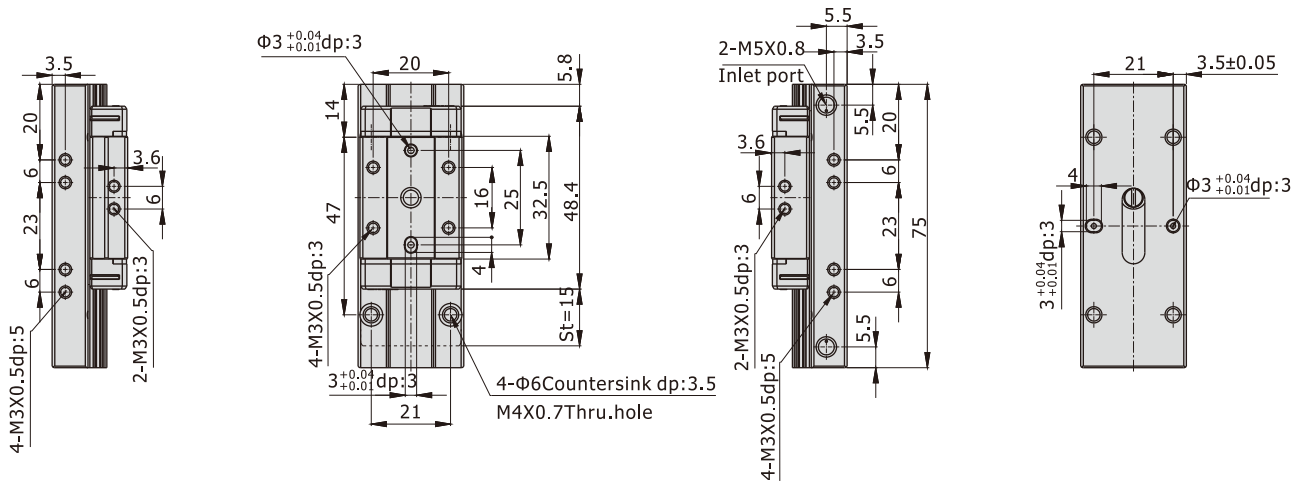

HGS10X15S

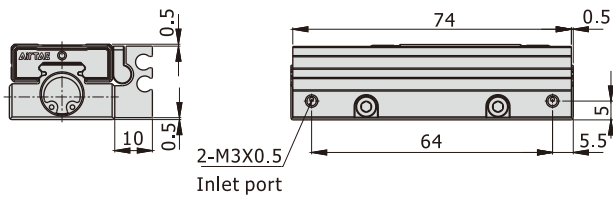

HGS10X15J Adjustable range :5mm of each sides.

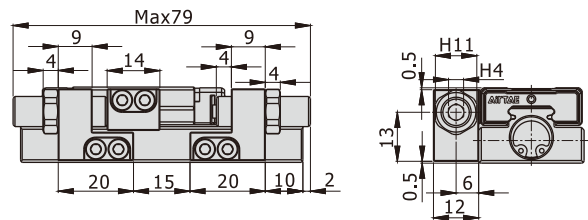

Slide table cylinder

HGS Series

Bore size: $\Phi 6$, $\Phi 8$, $\Phi 10$, $\Phi 12$

HGS10X20

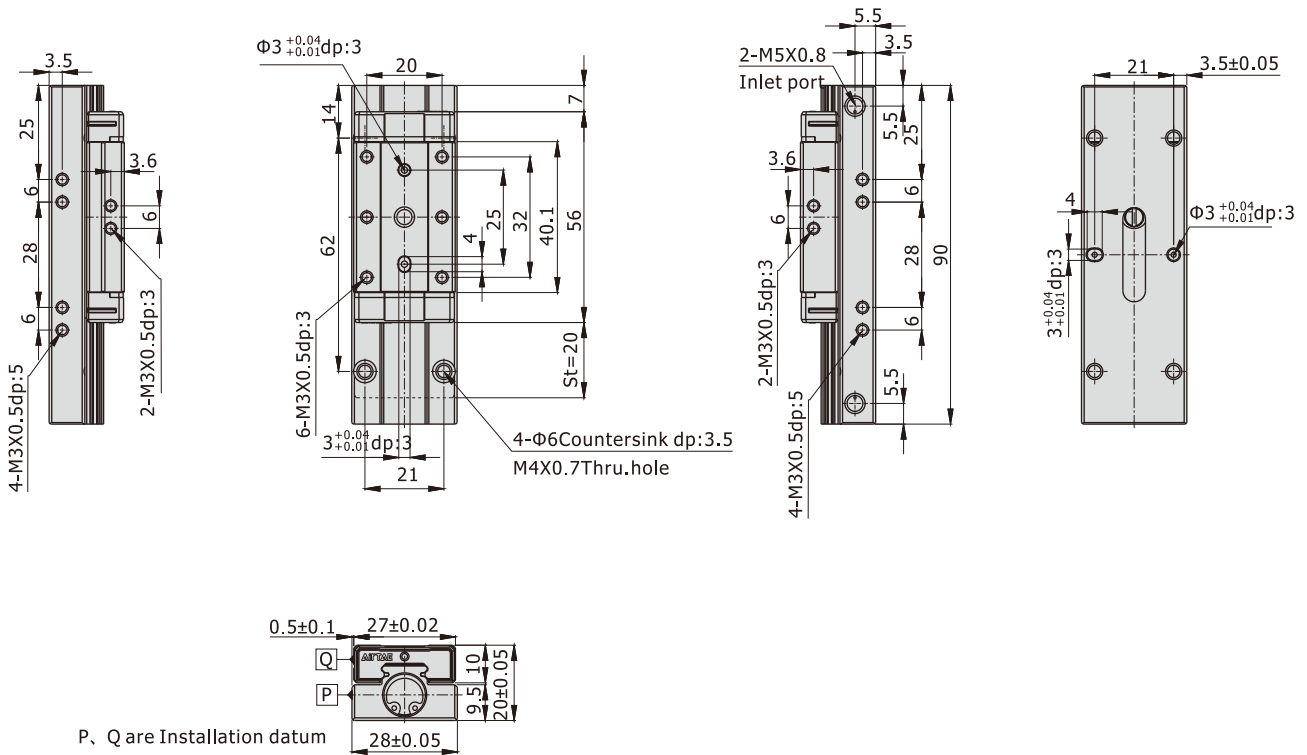

HGS10X20S

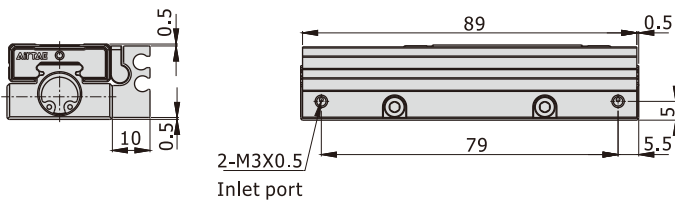

HGS10X20J Adjustable range :5mm of each sides.

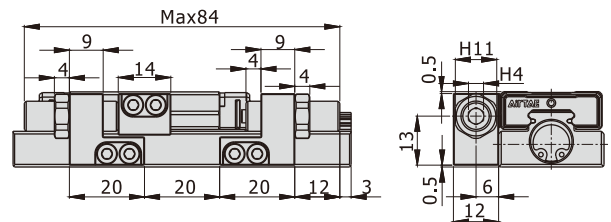

Slide table cylinder

HGS Series

Bore size: $\Phi 6$, $\Phi 8$, $\Phi 10$, $\Phi 12$

Dimensions(HGS12)

HGS12X5

[Unit: mm]

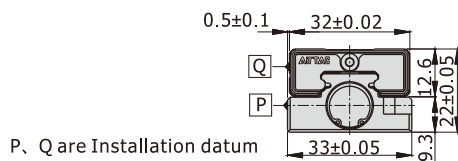
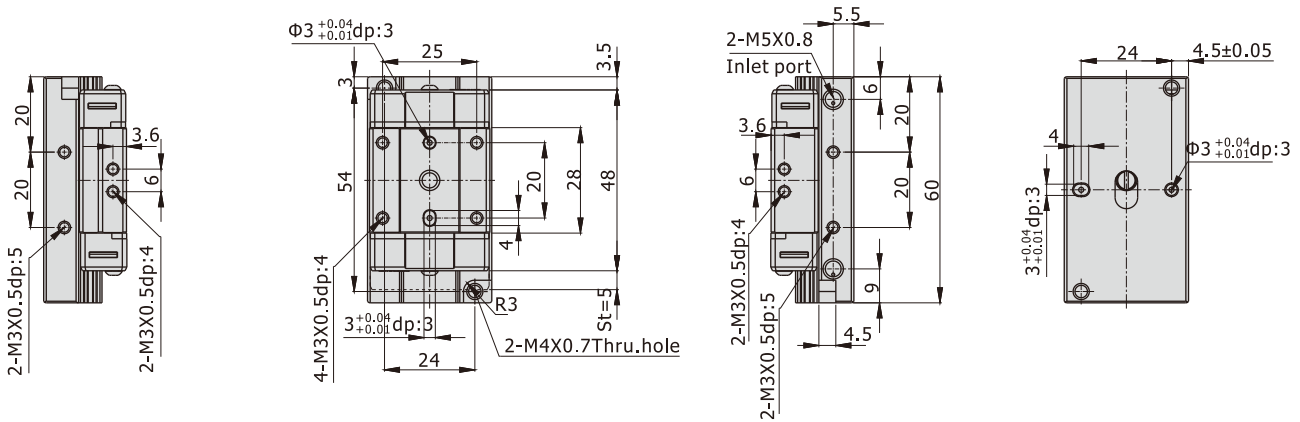

HGS12X5S

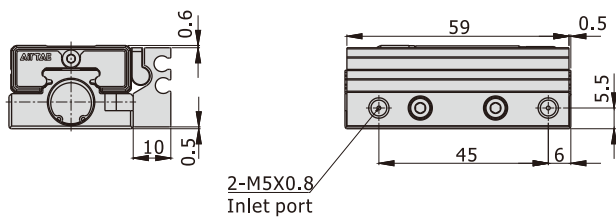

HGS12X5J

Adjustable range : 5mm

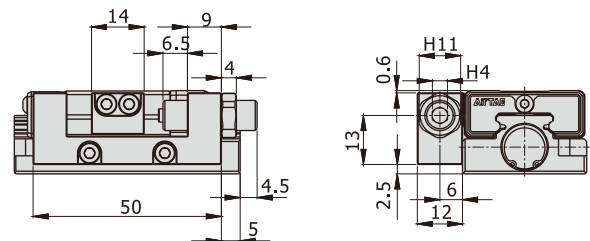

Slide table cylinder

HGS Series

Bore size: $\Phi 6$, $\Phi 8$, $\Phi 10$, $\Phi 12$

HGS12X10

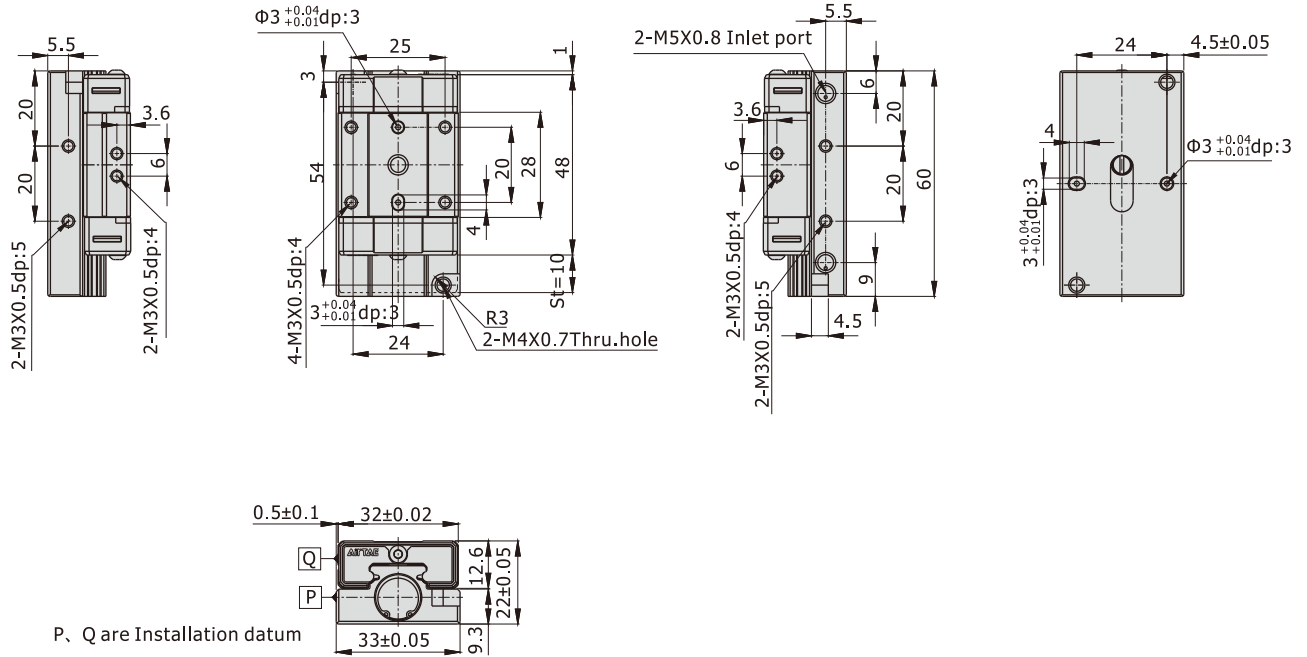

HGS12X10S

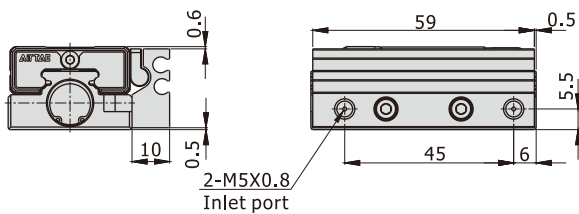

HGS12X10J Adjustable range :5mm of each side

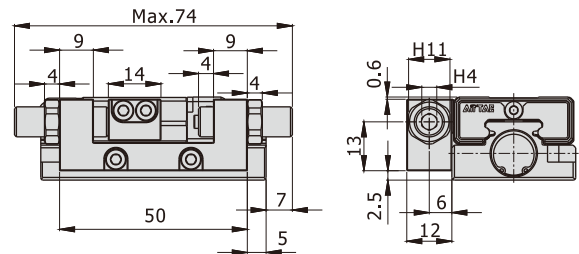

Slide table cylinder

HGS Series

Bore size: $\Phi 6$, $\Phi 8$, $\Phi 10$, $\Phi 12$

HGS12X15

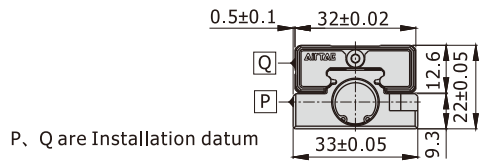
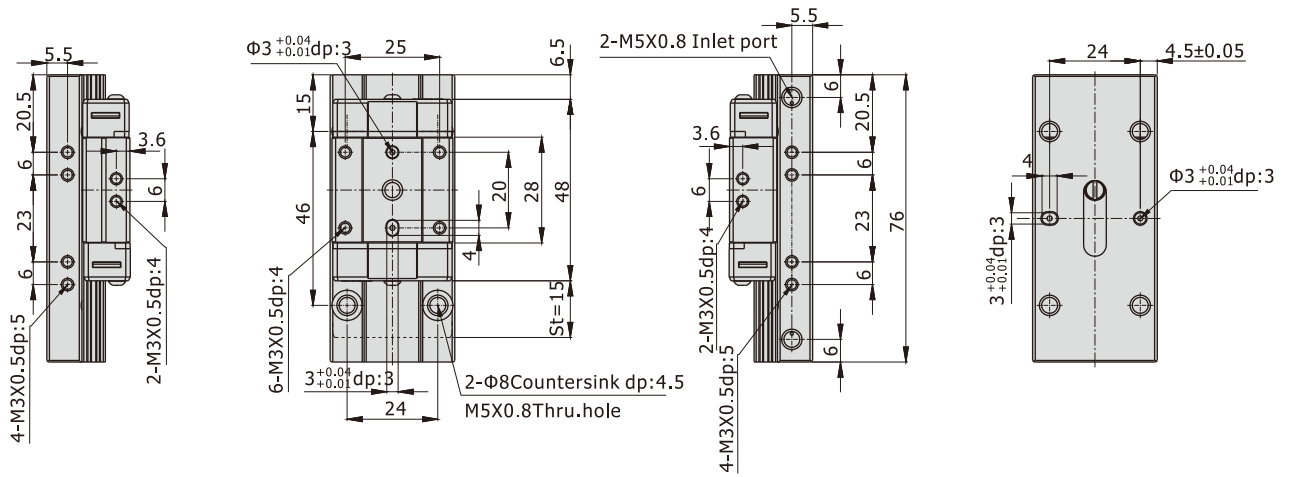

HGS12X15S

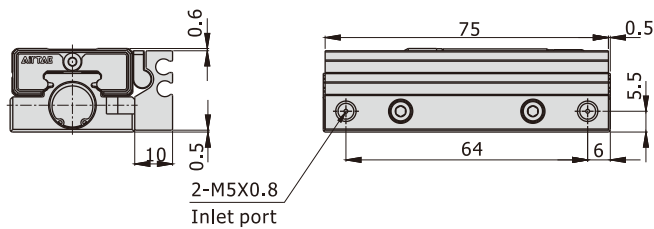

HGS12X15J Adjustable range :5mm of each side

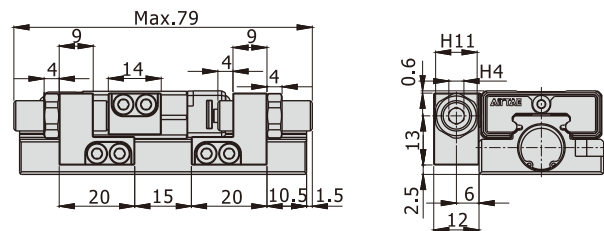

Slide table cylinder

HGS Series

Bore size: $\Phi 6$, $\Phi 8$, $\Phi 10$, $\Phi 12$

HGS12X20

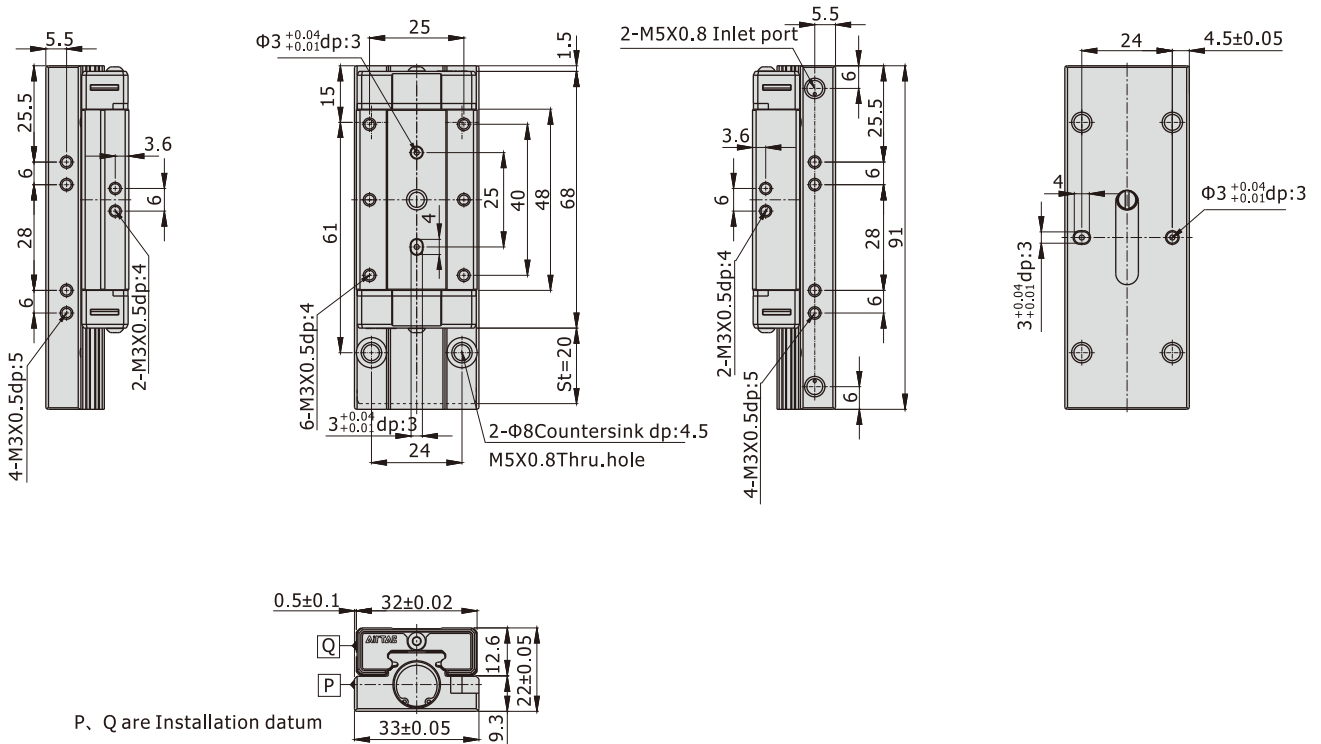

HGS12X20S

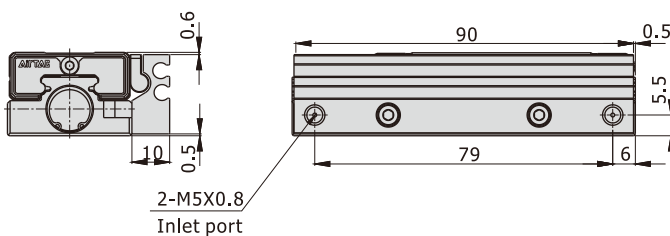

HGS12X20J Adjustable range :5mm of each side

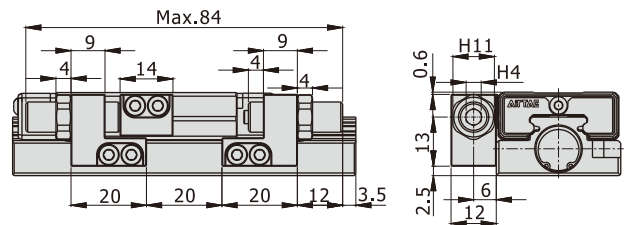

Slide table cylinder

HGS Series

Bore size: $\Phi 6$, $\Phi 8$, $\Phi 10$, $\Phi 12$

HGS12X25

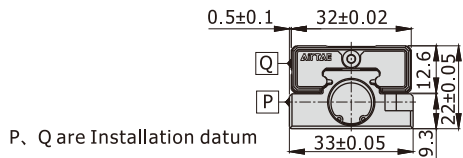
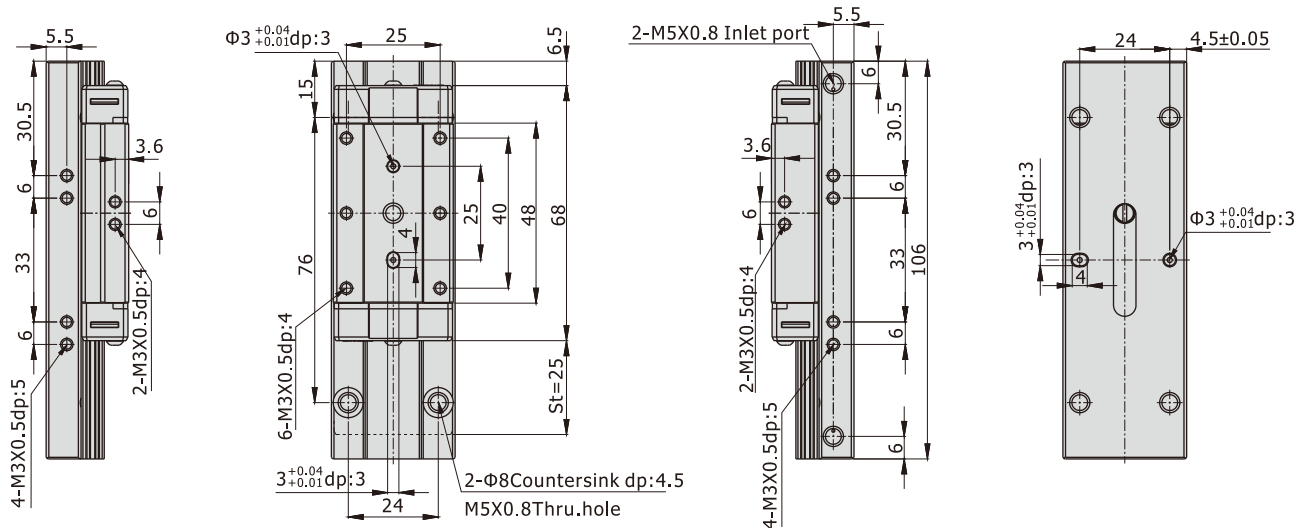

HGS12X25S

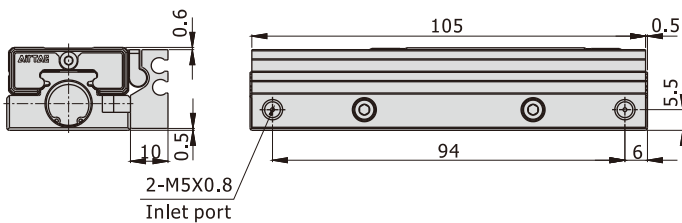

HGS12X25J Adjustable range :5mm of each side

