



# Twin-rod cylinder—TR Series

Bore size:  $\Phi 6$ ,  $\Phi 10$ ,  $\Phi 16$ ,  $\Phi 20$ ,  $\Phi 25$ ,  $\Phi 32$



## Ordering code

**TR 32×50 S T**

① ② ③ ④ ⑤

### ① Model

TR: Twin-rod cylinder  
(Double acting type)

### ② Bore size

6 10 16 20 25 32

### ④ Magnet [Note1]

S: With magnet

### ⑤ Thread type [Note 2]

T: NPT

### ③ Stroke [Note3]

Bore size (mm)	Standard stroke (mm)	Max.std stroke
6	10 20 30 40 50	50
10	10 20 30 40 50 60 70 80 90 100	100
16	10 20 30 40 50 60 70 80 90 100 125 150 175 200	200
20	10 20 30 40 50 60 70 80 90 100 125 150 175 200	200
25	10 20 30 40 50 60 70 80 90 100 125 150 175 200	200
32	10 20 30 40 50 60 70 80 90 100 125 150 175 200	200

[Note1] TR Series are all with magnet.

[Note2] When the thread is standard, the code is blank.

[Note3] When the stroke less then or equal to 100mm, The dimensions of non-std stroke cylinder has the same dimensions as the next longer stroke std. stroke cylinder. e.g. 35mm stroke cylinder has the same dimensions of 40 std. stroke cylinder.

## Specification

Bore size(mm)	6	10	16	20	25	32
Acting type	Double acting					
Fluid	Air(to be filtered by 40 $\mu$ m filter element)					
Operating pressure	29~145psi(0.2~1.0MPa)			22~145psi(0.15~1.0MPa)		
Proof pressure	215psi(1.5MPa)					
Temperature	-20~70°C					
Speed range mm/s	30~500					
Adjustable stroke mm	-5~0					
Stroke tolerance	$\leq 100 \begin{matrix} +1.0 \\ 0 \end{matrix}$ $> 100 \begin{matrix} +1.5 \\ 0 \end{matrix}$					
Cushion type	Bumper					
Non-rotating tolerance [Note1]	$\pm 0.2^\circ$	$\pm 0.15^\circ$				$\pm 0.1^\circ$
Port size [Note2]	M5×0.8					1/8

[Note1] Retract position.

[Note2] NPT thread is available.



# Twin-rod cylinder

## TR Series

Bore size:  $\Phi 6$ ,  $\Phi 10$ ,  $\Phi 16$ ,  $\Phi 20$ ,  $\Phi 25$ ,  $\Phi 32$

### Inner structure

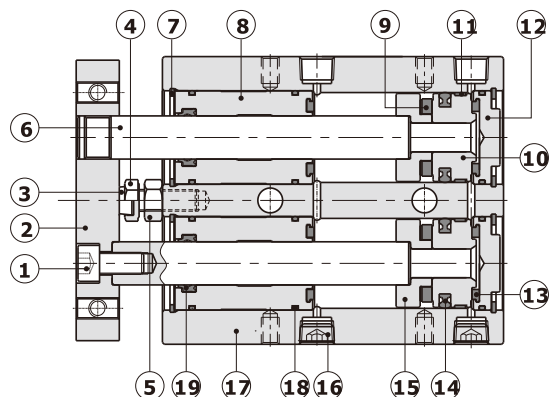

NO.	Item	NO.	Item
1	Screw	11	Wear ring
2	Fixing plate	12	Back cover
3	Bumper	13	Bumper
4	Screw	14	Piston seal
5	Nut	15	Magnet holder
6	Piston rod	16	Screw
7	C clip	17	Body
8	Front cover	18	Back cover O-ring
9	Magnet	19	Spool O-ring
10	Piston		

### Criteria for selection: Cylinder thrust

Unit: Newton(N)

Bore size	Rod size	Acting type	Pressure area(mm <sup>2</sup> )	Operating pressure(psi)							
				15	30	45	60	75	90	105	
6	4	Double acting	Push side	56.5	5.7	11.3	17.0	22.6	28.3	33.9	39.6
			Pull side	31.4	3.1	6.3	9.4	12.6	15.7	18.8	22.0
10	6	Double acting	Push side	157.1	15.7	31.4	47.1	62.8	78.6	94.3	110.0
			Pull side	100.5	10.1	20.1	30.2	40.2	50.3	60.3	70.4
16	8	Double acting	Push side	402.1	40.2	80.4	120.6	160.8	201.1	241.3	281.5
			Pull side	301.6	30.2	60.3	90.5	120.6	150.8	181.0	211.1
20	10	Double acting	Push side	628.3	62.8	125.7	188.5	251.3	314.2	377.0	439.8
			Pull side	471.2	47.1	94.2	141.4	188.5	235.6	282.7	329.8
25	12	Double acting	Push side	981.7	98.2	196.4	294.5	392.7	490.9	589.0	687.2
			Pull side	755.6	75.6	151.1	226.7	302.2	377.8	453.4	528.9
32	16	Double acting	Push side	1608.5	160.9	321.7	482.6	643.4	804.3	965.1	1126.0
			Pull side	1206.4	120.6	241.3	361.9	482.6	603.2	723.8	844.5

# Twin-rod cylinder

## TR Series

Bore size:  $\Phi 6$ ,  $\Phi 10$ ,  $\Phi 16$ ,  $\Phi 20$ ,  $\Phi 25$ ,  $\Phi 32$

### Dimensions

#### TR6~16

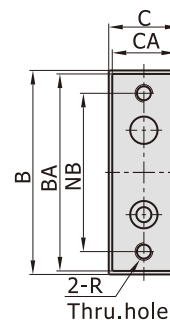
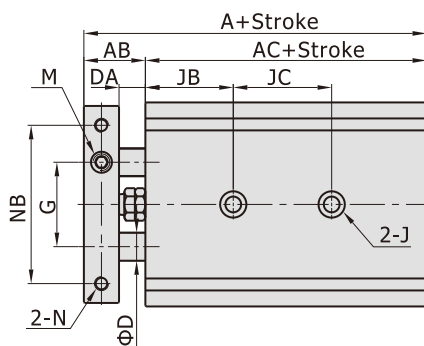
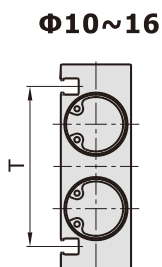
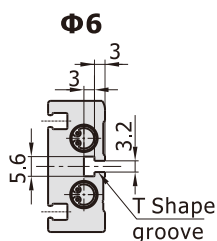
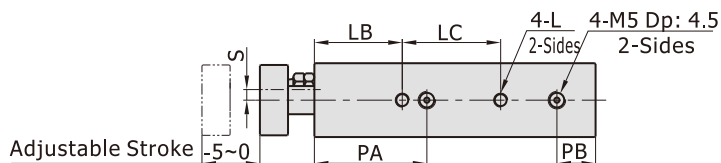
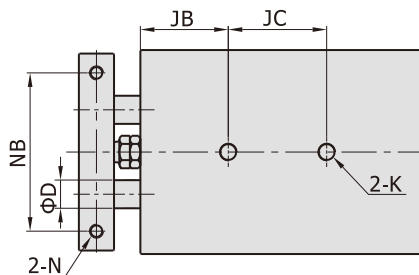

[Unit: mm]

Bore size\Item Stroke	A	AB	AC	B	BA	C	CA	D	DA	G	JC LC							T	
											10~25	30~50	60~80	90~100	125	150	175		200
6	58.5	13.5	45	37	35	16	14	4	8	16	JC=10+Stroke/2		-	-	-	-	-	-	23
											LC=13+Stroke								
10	72	17	55	46	44	17	15	6	9	20	30	40	50	60	-	-	-	-	36.5
16	79	19	60	58	56	20	18	8	9	25	25	35	45	55	65	75	145	145	46.5

Bore size\Item	J	JB	K	L	LB	M
6	One side: $\Phi 6.5$ Dp:3.5Thru.hole: $\Phi 3.5$	13	-	M3 $\times$ 0.5Dp:4.5	10	M3 $\times$ 0.5
10	One side: $\Phi 6.5$ Dp:3.5Thru.hole: $\Phi 3.5$	20	M4 $\times$ 0.7Thru.hole	M3 $\times$ 0.5Dp:5	20	M5 $\times$ 0.8
16	One side: $\Phi 8.0$ Dp:4.5Thru.hole: $\Phi 4.5$	30	M5 $\times$ 0.8Thru.hole	M4 $\times$ 0.7Dp:5	30	M6 $\times$ 1.0

Bore size\Item	N	NB	PA	PB	R	S
6	M3 $\times$ 0.5Thru.hole	28	24.5	6.5	M3 $\times$ 0.5	4.5
10	M3 $\times$ 0.5Dp:7.5	35	30	8	M4 $\times$ 0.7	3.5
16	M4 $\times$ 0.7Thru.hole	45	38	8	M5 $\times$ 0.8	5

# Twin-rod cylinder

## TR Series

Bore size:  $\Phi 6$ ,  $\Phi 10$ ,  $\Phi 16$ ,  $\Phi 20$ ,  $\Phi 25$ ,  $\Phi 32$

### TR20~32

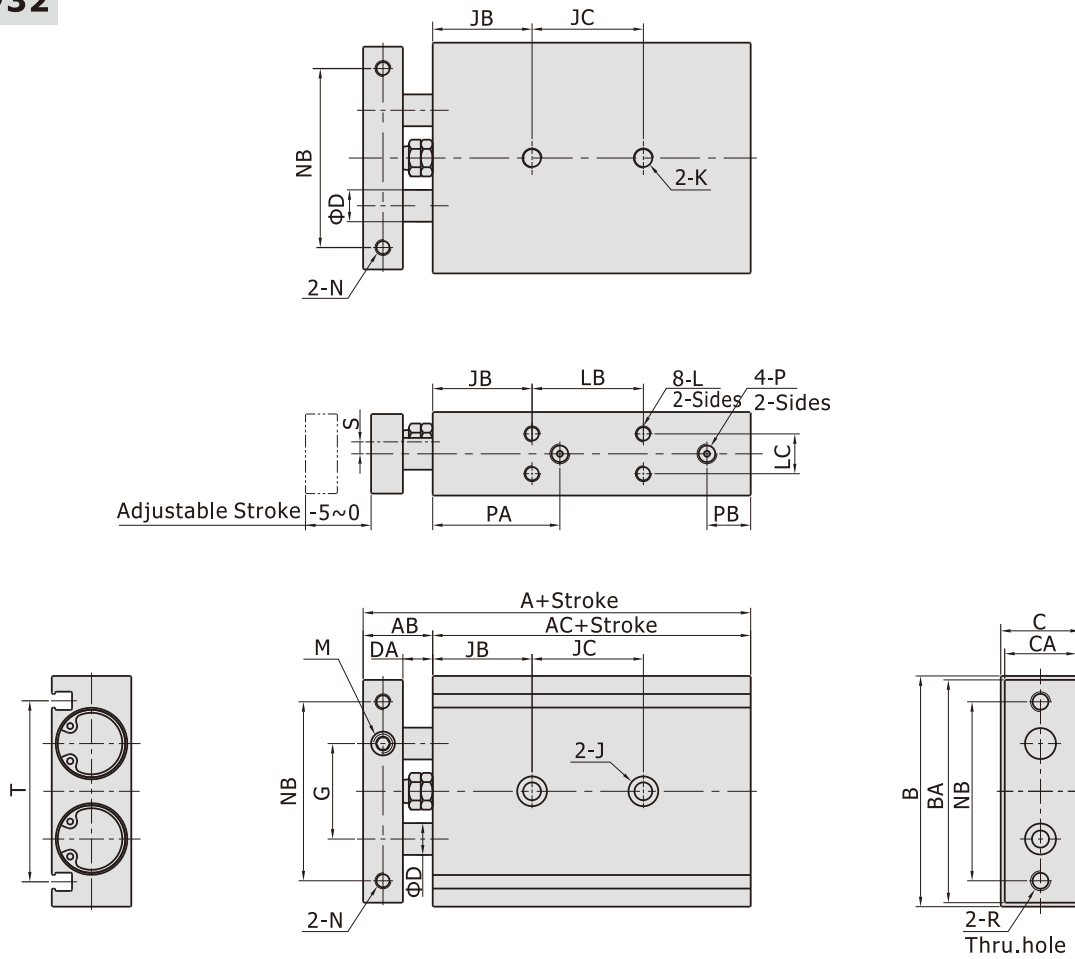

[Unit: mm]

Bore size/Item Stroke	A	AB	AC	B	BA	C	CA	D	DA	G	JB	JC LB						
												10~25	30~50	60~100	125	150	175	200
20	94	24	70	64	62	25	23	10	12	28	30	30	40	60	80	80	100	100
25	96	24	72	80	78	30	28	12	12	35	30	30	40	60	80	80	100	100
32	112	30	82	98	96	38	36	16	14	44	30	40	50	70	90	90	110	110

Bore size/Item	P	PA	PB	J	K	L	LC
20	M5×0.8	46	9	One side: $\Phi 9.5$ Dp:5.5 Thru.hole: $\Phi 5.5$	M6×1.0 Thru.hole	M4×0.7Dp:5.5	9.5
25	1/8"	43	9	One side: $\Phi 11$ Dp:6.5 Thru.hole: $\Phi 7$	M8×1.25 Thru.hole	M5×0.8Dp:7	13
32	1/8"	53	10	One side: $\Phi 11$ Dp:6.5 Thru.hole: $\Phi 7$	M8×1.25 Thru.hole	M5×0.8Dp:7	20

Bore size/Item	M	N	NB	R	S	T
20	M8×1.25	M4×0.7Dp:6	50	M5×0.8	6.5	52
25	M8×1.25	M5×0.8Dp:7.5	60	M6×1.0	9	61
32	M10×1.5	M5×0.8Dp:8	75	M6×1.0	11.5	73

### Installation and application

#### 1. How to mount workpiece.

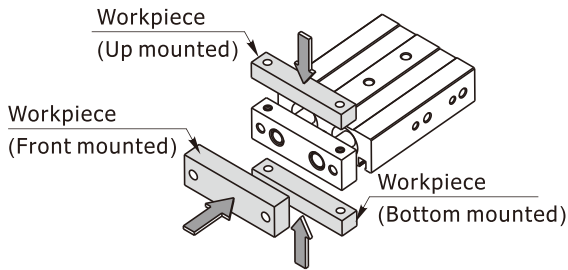

How to mount the workpiece

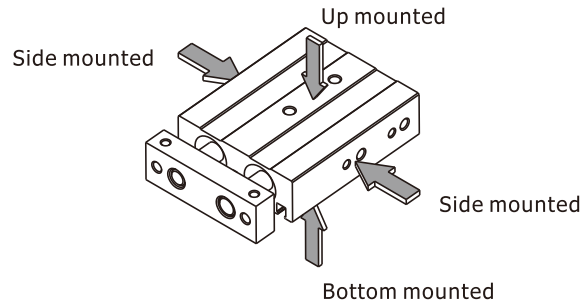

How to mount the cylinder

#### 2. Max. weight of allowable side-load

##### Mounting type

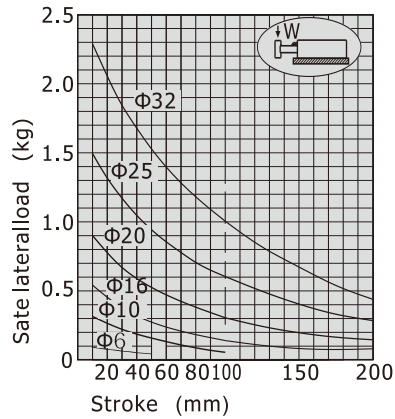
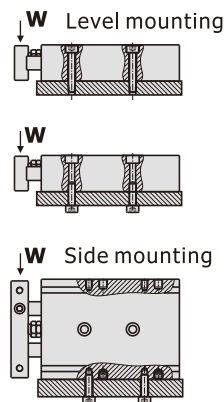

#### 3. Safe deflection

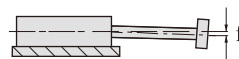
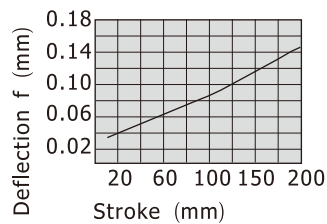

The average value of deflection of rod end of the whole series basically stays in the line showed in the chart on the left.