

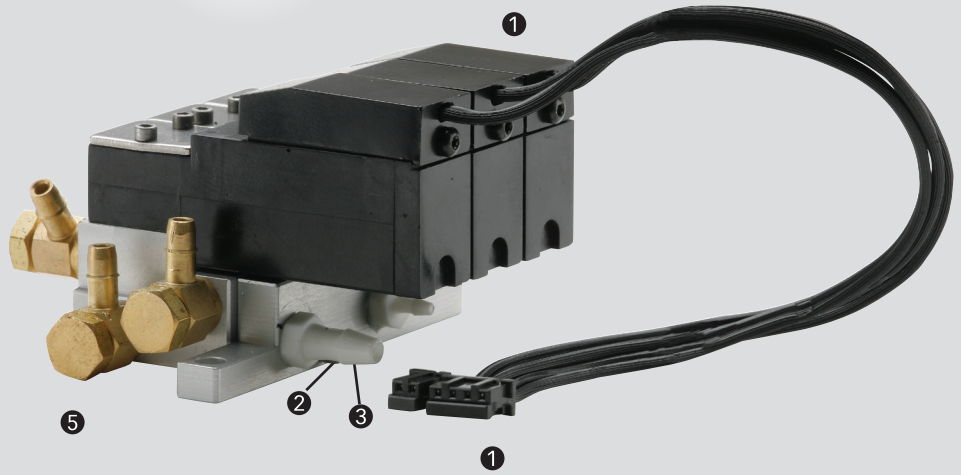

Humphrey's custom valve manifold met the target flow rate, spatial requirements, low current consumption and life cycle performance. This enabled the customer to create a lightweight, portable oxygen concentrator, eliminating the need to pull relatively heavy oxygen tanks with limited supply.



- ① Modified Humphrey HK5 direct-acting solenoid valves
- ② Custom manifold with special port & mounting configurations
- ③ Humphrey Quick Exhaust check valve (inside manifold)
- ④ Electronic connection
- ⑤ Adjustable elbow fittings reduce overall package size

## Custom Valve Manifold Key to New Portable Oxygen Concentrator



**MEDICAL**  
SIC:3842

### THE CUSTOMER'S PRODUCT

- The customer designs and manufactures a range of respiratory and rehabilitative care equipment designed to help patients at all stages of respiratory distress.
- Recognizing a need for a portable oxygen concentrator to replace the relatively heavy and cumbersome portable oxygen tanks, the customer began developing a prototype using a lapped-spool valve. Since the unit would be battery powered, low current consumption was critical. The goal was to produce a small, compact unit with up to four hours of battery life.
- When the size and leak rate of the spool valve proved unacceptable, the customer turned to the Humphrey Engineered Solutions team.

### THE REQUIREMENTS

- Three-valve manifold assembly meeting extremely tight space and total weight requirements, with custom mounting locations.
- All valves must meet the target flow rates and have a low current consumption.
- The valves must meet a four million life cycle test.
- Valve assemblies to be shipped to meet an extremely short production deadline.
- Custom manifold with three HK5 diaphragm/poppet solenoid valves having virtually zero leakage.

### THE HUMPHREY ENGINEERED SOLUTION

- Two of the HK5 valves modified for 0.8 Watts current consumption, for overall current consumption of 3.2 Watts.
- Modified Humphrey Quick Exhaust valves with the unique shuttle design used as check valves achieved target cracking pressure of 1 PSIG or less.
- Special low profile fittings were used to reduce the overall package size.
- Valve assembly tested to six million cycles without failure.
- Tested production valve assemblies delivered to customer on time.

## THE SOLUTION

Working with the customer's engineering department, the Humphrey Engineered Solutions team developed a valve manifold assembly that met all the requirements.

The three HK5 valves provided different functions. One controlled patient oxygen delivery with a sensor circuit, providing oxygen only when the patient was inhaling. The other two HK5 valves – a pressure equalization valves and a bleed valve – controlled the production of oxygen in the sieve bed, where nitrogen atoms are removed from the atmospheric air.

Since the standard Humphrey HK5 valve met the customer's target flow rate, the only modifications were to the HK5 pressure equalization and bleed valves to reduce their current consumption. Humphrey modified their Quick Exhaust valve to function as a check valve by plugging the exhaust port and using a custom elastomer compound to achieve the target cracking pressure of 1 PSIG or less.

## THE PROCESS

The customer was very familiar with the simplicity of Humphrey valves, and when the Humphrey Engineered Solutions team contacted the customer's engineering department, the challenge was issued: Provide a low leakage valve manifold assembly that met target flow rates, current consumption, and extremely tight size and weight requirements.

As the design progressed from concept to prototype, the customer modified key flow rate specifications. Since the customer's existing valve supplier was unable to meet those requirements, Humphrey was given the opportunity – and a very short deadline.

Working closely with the customer's engineering department, the Humphrey Engineered Solutions team met the challenges. The first requirement was being able to adjust the internal orifice sizes in the manifold quickly to enable the customer to fine-tune the design. Then Humphrey modified two of the three HK5 valves to reduce current consumption, modified their Quick Exhaust shuttle to achieve the target cracking pressure, utilized low profile fittings to reduce the overall package size and created a custom manifold – plus delivered the 100% tested assemblies on time.

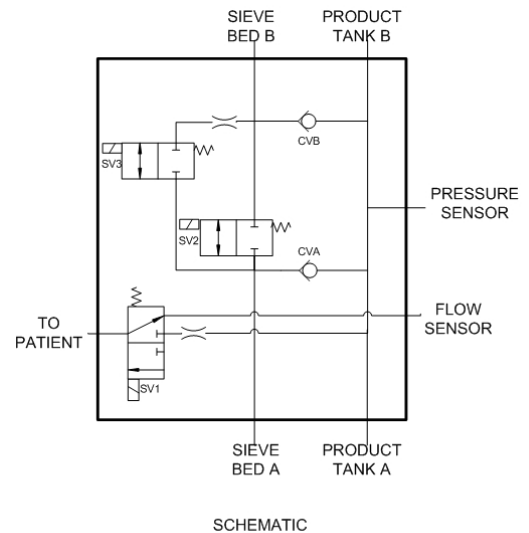
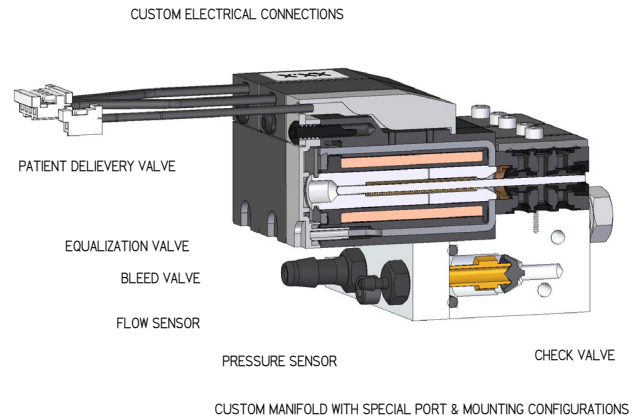
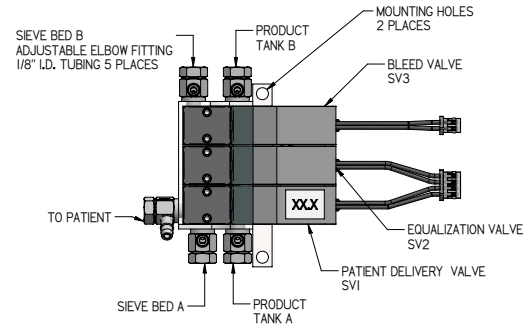

**Humphrey**

BUILD ON OUR EXPERIENCE