

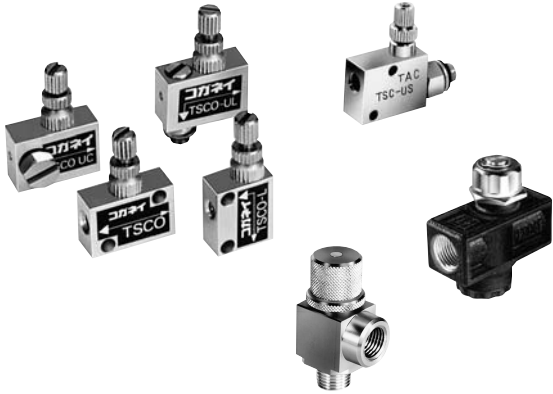

CAD drawing data catalog is available.



KOGANEI

ACCESSORIES GENERAL CATALOG

AIR TREATMENT, AUXILIARY, VACUUM, AND FLUORORESIN PRODUCTS

SPEED CONTROLLERS CONTENTS

Speed Controllers

TSCO Series

Specifications, Inner Construction and Major Parts	539
Order Codes, Dimensions	540

HTSC Series

Specifications, Order Codes, Inner Construction and Major Parts	541
Dimensions	542

HSC Series

Specifications, Order Codes, Inner Construction and Major Parts	543
Dimensions	544

HSCL Series

Specifications, Inner Construction and Major Parts, Order Codes	545
Dimensions	546

KSC-F11 Series

Specifications, Order Codes, Inner Construction and Major Parts	547
Dimensions	548



Caution

Before use, be sure to read the "Safety Precautions" on p. 49.

SPEED CONTROLLERS TSCO SERIES

M3×0.5



- Offer fine speed control for the M3 ported Pen Cylinders.
- Compact, lightweight, and easy to handle.

Specifications

Item	Model	TSCO	TSCO-L	TSCO-UC	TSCO-UL
Piping type	Controlled flow P	Female thread		Universal male thread	
	Controlled flow A	Female thread			
Port size		M3×0.5			
Media		Air			
Operating pressure range	MPa [psi.]	0~0.7 [0~102]			
Proof pressure	MPa [psi.]	1.03 [149]			
Cracking pressure	MPa [psi.]	0.05 [7.3]			
Operating temperature range	°C [°F]	5~60 [41~140]			
Mass	g [oz.]	5 [0.18]	4 [0.14]	6 [0.21]	6 [0.21]

Symbol

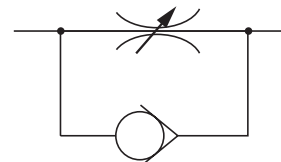

Flow Rate Characteristics

● Controlled flow

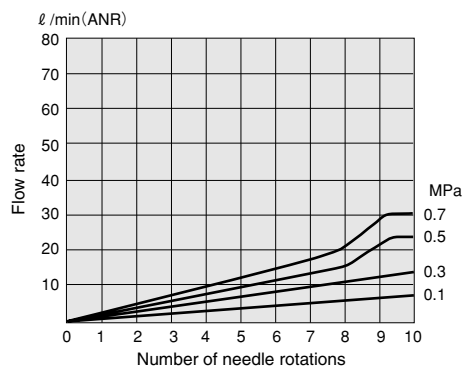

● Free flow

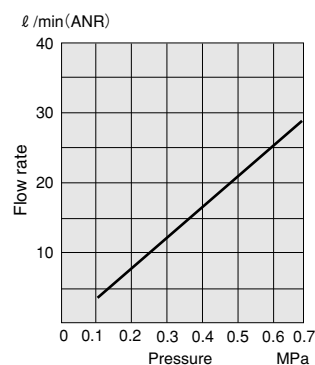

1MPa = 145psi. 1 l/min = 0.0353ft³/min.

Inner Construction and Major Parts

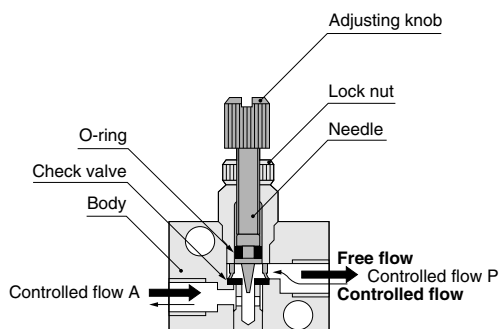

Major Parts and Materials

Parts	Materials
Body	Brass (nickel plated)
Needle	Stainless steel
Lock nut	Brass (nickel plated)
Check valve	Synthetic rubber (NBR)
O-ring	
Adjusting knob	Brass (nickel plated)

Order Codes

Model	Non-ion specification	
TSCO	Blank	Standard specification
TSCO-L	NCU	Non-ion specification
TSCO-UC		
TSCO-UL		

Dimensions (mm)

TSCO

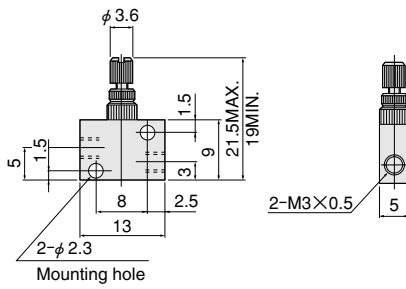

TSCO-L

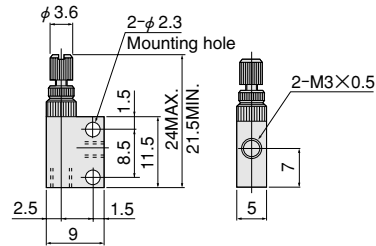

TSCO-UC

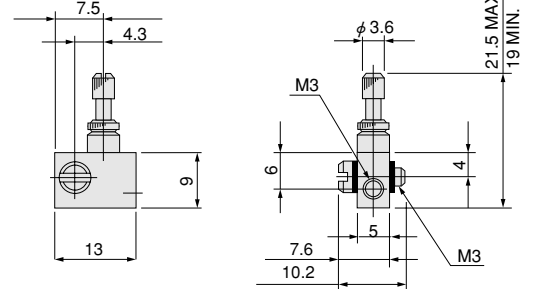

TSCO-UL

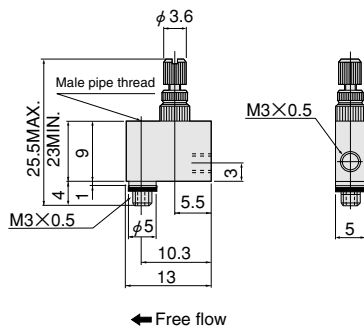

Handling Instructions and Precautions

- Always use fingertips to rotate and tighten the lock nut and needle. Use of excessive tightening force with tools, etc., could cause damage to the units.
- When using a universal male thread type for piping, secure at the male pipe thread portion. The tightening torque should not exceed 0.5N · m [4.4in · lbf].

SPEED CONTROLLERS HTSC SERIES

10-32 UNF, With Clamp Fitting

- Compact and lightweight, optimum for Pen Cylinders and Jig Cylinders.
- Wide variation of products allows mounting in any direction.
- Straight type and L type offer a choice of piping directions.

Symbol

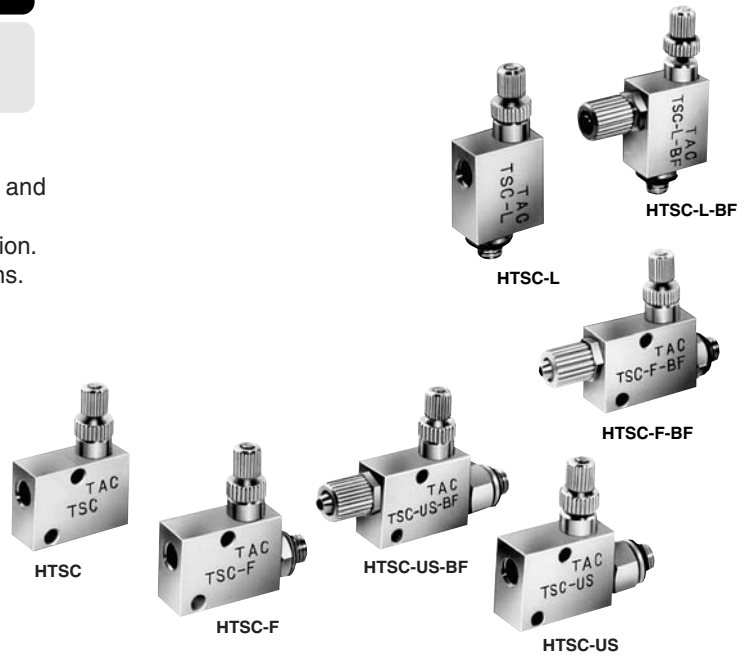
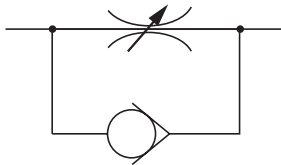

Specifications

Item	Model	HTSC	HTSC-F	HTSC-F-BF	HTSC-US	HTSC-US-BF	HTSC-L	HTSC-L-BF
Piping type and port size	Controlled flow P	Female thread 10-32 UNF	Male thread 10-32 UNF		Union male thread 10-32 UNF		Male thread 10-32 UNF	
	Controlled flow A	Female thread 10-32 UNF		For urethane tube $\phi 4 \times 2.5$ Clamp fitting	Female thread 10-32 UNF	For urethane tube $\phi 4 \times 2.5$ Clamp fitting	Female thread 10-32 UNF	For urethane tube $\phi 4 \times 2.5$ Clamp fitting
Media		Air						
Operating pressure range	MPa [psi.]	0~0.9 [0~131]						
Proof pressure	MPa [psi.]	1.32 [191]						
Cracking pressure	MPa [psi.]	0.05 [7.3]						
Operating temperature range	°C [°F]	5~60 [41~140]						
Mass	g [oz.]	16 [0.56]	18 [0.63]	20.5 [0.72]	19 [0.67]	21.5 [0.76]	15 [0.53]	17 [0.60]

Order Codes



- Model
 HTSC
 HTSC-F
 HTSC-F-BF
 HTSC-US
 HTSC-US-BF
 HTSC-L
 HTSC-L-BF

Inner Construction and Major Parts

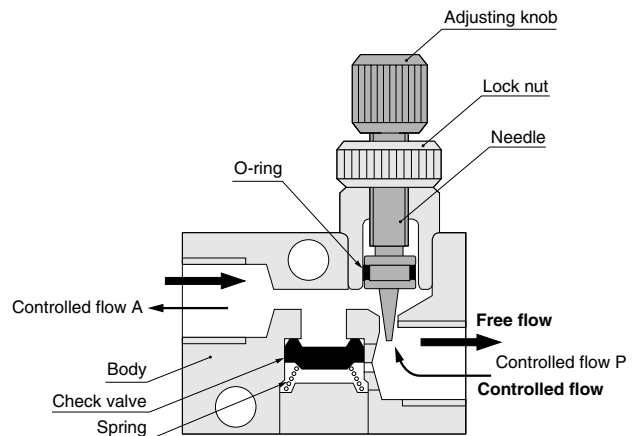

Major Parts and Materials

Parts	Materials
Body	Brass (nickel plated)
Needle	Stainless steel
Lock nut	Brass (nickel plated)
Check valve	Synthetic rubber (NBR)
O-ring	
Adjusting knob	Brass (nickel plated)

Dimensions (mm)

● Straight type

● HTSC

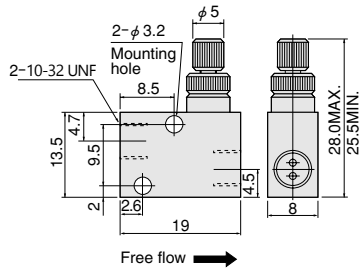

● HTSC-F

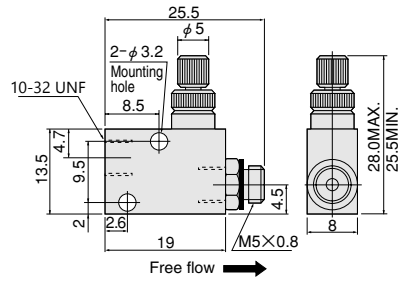

● HTSC-F-BF

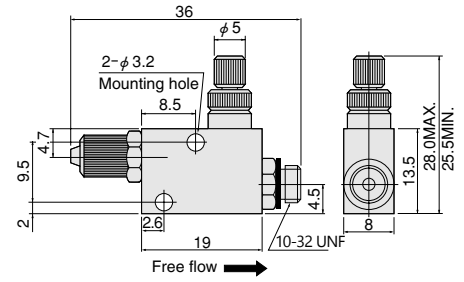

● HTSC-US

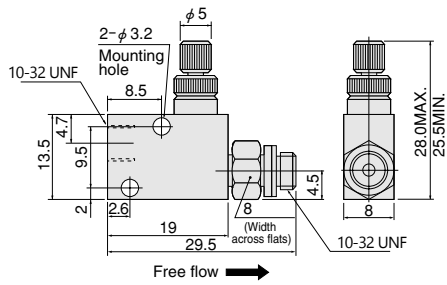

● HTSC-US-BF

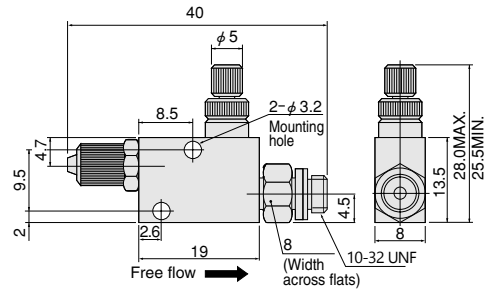

● L type

● HTSC-L

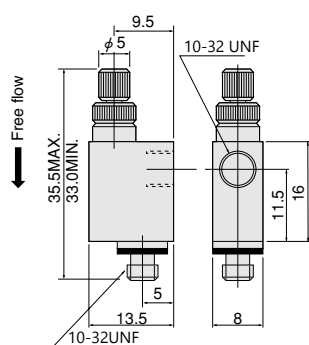

● HTSC-L-BF

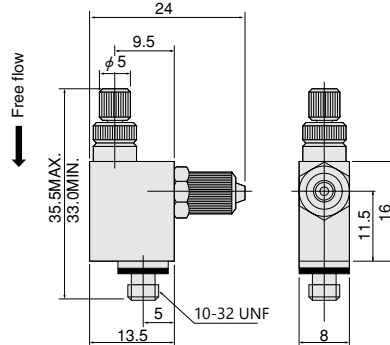

Flow Rate Characteristics

● Controlled flow

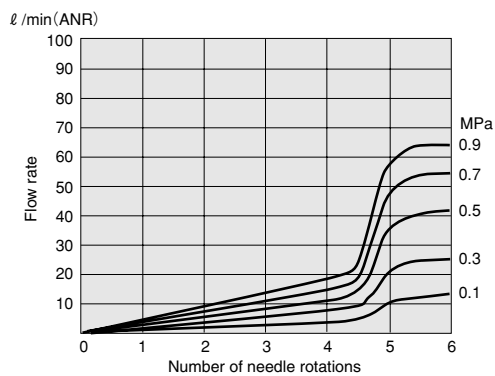

1MPa = 145psi. 1 l/min = 0.0353ft³/min.

● Free flow

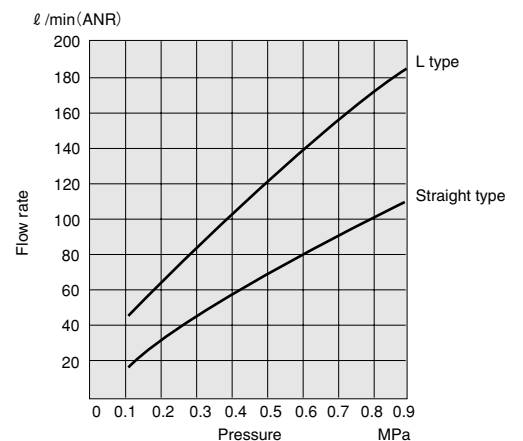

SPEED CONTROLLERS HSC SERIES

10-32 UNF, NPT1/8

- Compact and lightweight, optimum for Pen Cylinders, Jig Cylinders, and Slim Cylinders.
- Straight type and L type offer mounting in any direction.
- Union type allows piping and needle setting in any direction.

Symbol

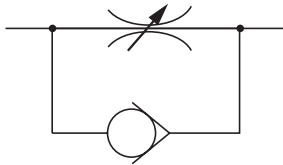

Specifications

Item	Model	HSC0	HSC0-F	HSC0-US	HSC0-UL	HSC1	HSC2
Piping type		Female thread	Male thread	Union male thread Straight Elbow		Female thread	
Port size		10-32 UNF					NPT1/8
Operating pressure range	MPa [psi.]	0~0.9 [0~131]					
Proof pressure	MPa [psi.]	1.32 [191]					
Cracking pressure	MPa [psi.]	0.05 [7.3]				0.04 [5.8]	0.03 [4.4]
Operating temperature range	°C [°F]	5~60 [41~140]					
Mass	g [oz.]	30 [1.06]	35 [1.23]	36 [1.27]	88 [3.10]	55 [1.94]	

Order Codes

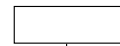

Model

HSC0
HSC0-F
HSC0-US
HSC0-UL
HSC1
HSC2

Inner Construction and Major Parts

● HSC0

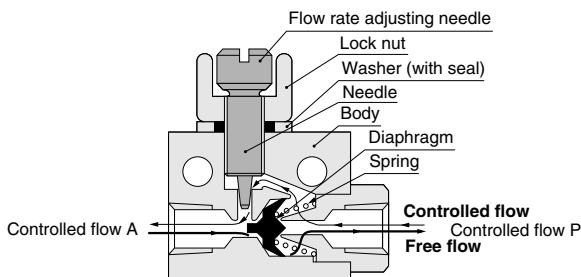

● HSC1

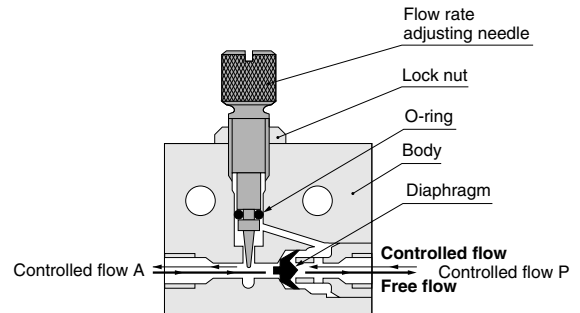

● HSC2

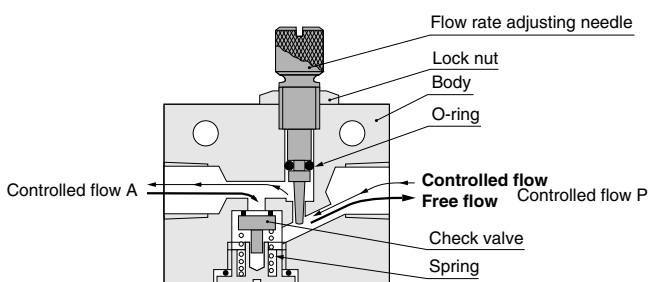

Major Parts and Materials

Parts	Materials
Body	Brass (nickel plated) ^{Note}
Needle	Stainless steel
Lock nut	Brass (nickel plated)
Check valve	Synthetic rubber (NBR)
O-ring	
Flow rate adjusting needle	Brass (nickel plated)

Note :SC2 is made of aluminum alloy (anodized).

Dimensions (mm)

● HSC0

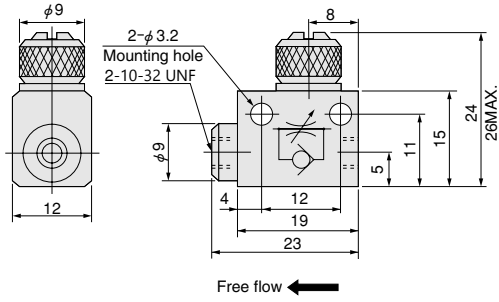

● HSC0-US

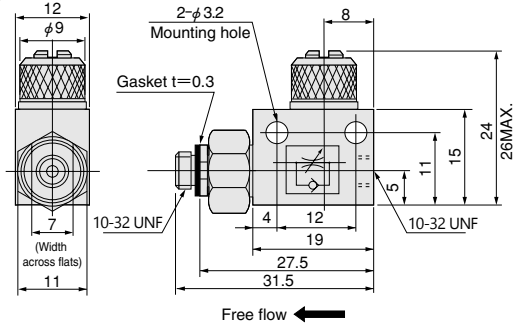

● HSC0-F

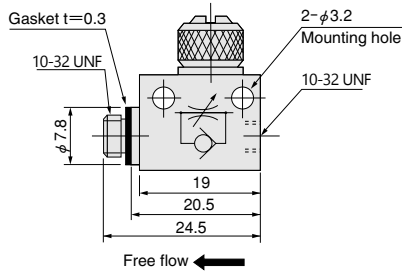

● HSC0-UL

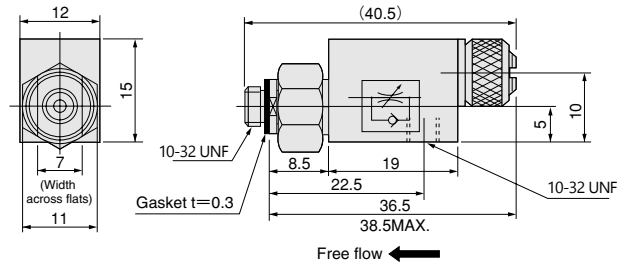

● HSC1

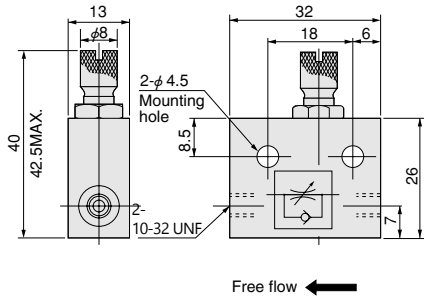

● HSC2

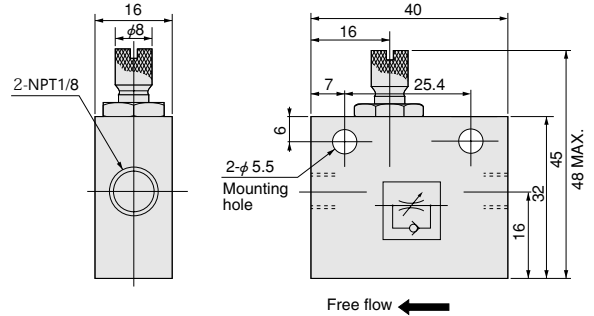

Flow Rate Characteristics

● HSC0

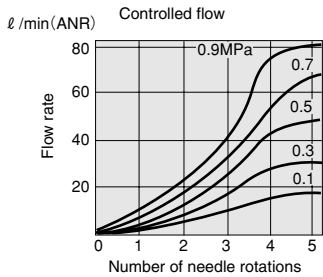

● HSC1

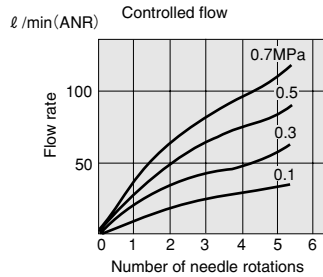

● HSC2

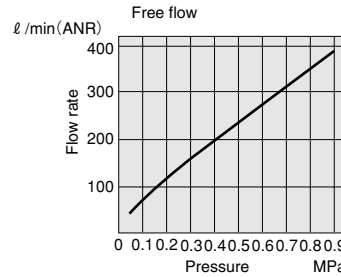
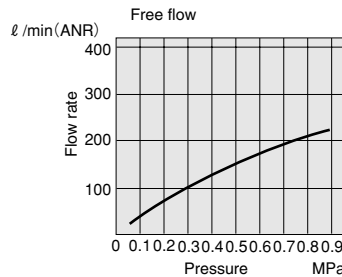
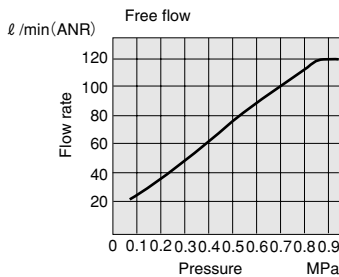
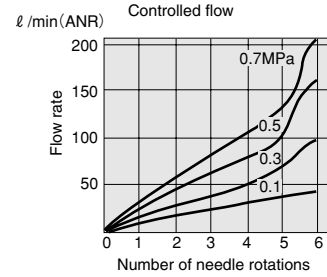

1 MPa = 145psi.
1 l/min = 0.0353ft³/min.

SPEED CONTROLLERS HSCL SERIES

Male thread, NPT1/8, NPT1/4
Female thread, NPT1/8, NPT1/4

- Compact and lightweight, optimum for Slim Cylinders, etc.
- Enables direct connection to cylinder connection ports, eliminating the piping work and materials.
- Can install L shaped piping to maintain compact piping setups.

Symbol

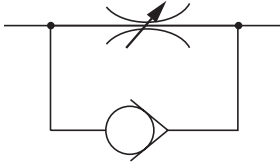

HSCL1

HSCL2

Specifications

Item	Model	HSCL1	HSCL2
Mounting type		Male thread specification, enabling direct cylinder mounting	
Port size		NPT1/8 Controlled flow P: male thread A: female thread NPT1/8	NPT1/4 Controlled flow P: male thread A: female thread NPT1/4
Media		Air	
Operating pressure range	MPa [psi.]	0~0.9 [0~131]	
Proof pressure	MPa [psi.]	1.32 [191]	
Cracking pressure	MPa [psi.]	0.06 [8.7]	
Operating temperature range	°C [°F]	5~60 [41~140]	
Mass	g [oz.]	46 [1.62]	125 [4.41]
Materials	Body	Brass (nickel plated)	
	Needle	Stainless steel	
	Seal	Synthetic rubber (NBR)	

Inner Construction and Major Parts

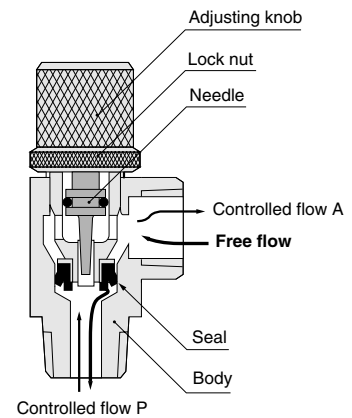

Order Codes



Model
HSCL1
HSCL2

Dimensions (mm)

● HSCL1

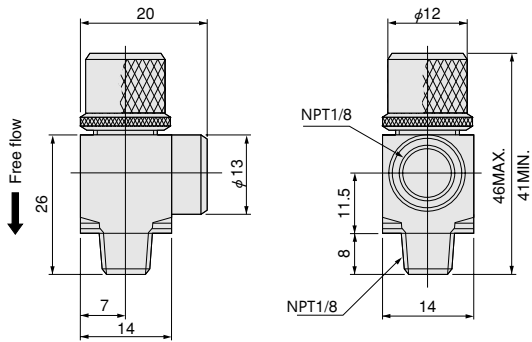

● HSCL2

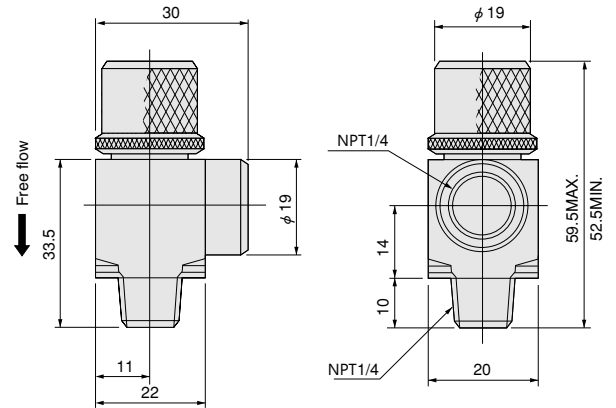

Flow Rate Characteristics

● HSCL1

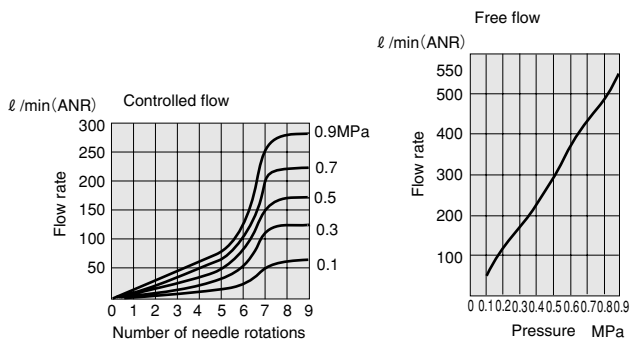

1MPa = 145psi. 1 ℓ/min = 0.0353ft³/min

● HSCL2

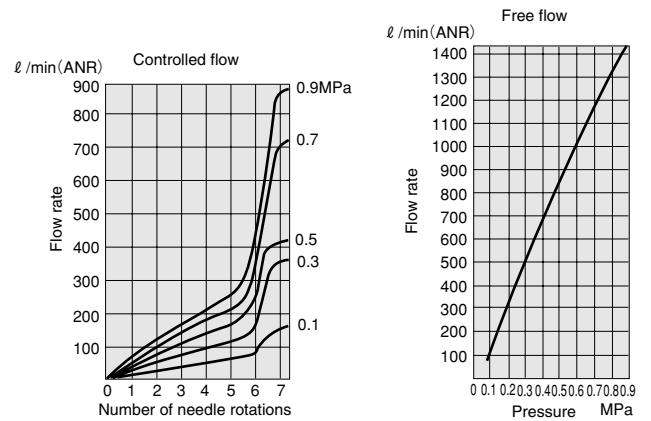

1MPa = 145psi. 1 ℓ/min = 0.0353ft³/min.

SPEED CONTROLLERS KSC SERIES

NPT1/4 ~ NPT1

- Easy to adjust flow rate.
- Maintain stable flow rate.
- Compact and easy mounting.

Symbol

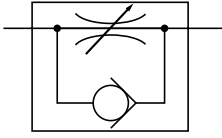

KSC41-F11



KSC22-F11



KSC8-F11

Specifications

Item	Model	KSC22-F11	KSC21-F11	KSC31-F11	KSC41-F11	KSC6-F11	KSC8-F11
Port size	NPT	1/4		3/8	1/2	3/4	1
Effective area	mm ²	10 [0.56]	32 [1.78]	38 [2.11]	38 [2.11]	67 [3.72]	90 [5]
	[Cv]	6.5 [0.36]	22 [1.22]	22 [1.22]	22 [1.22]	62 [3.44]	103 [5.72]
Operating pressure range	MPa [psi.]	0.9 [131]					
Proof pressure	MPa [psi.]	1.3 [189]					
Cracking pressure	MPa [psi.]	0.02 [2.9]			0.01 [1.5]		
Operating temperature range	°C [°F]	5 ~ 60 [41 ~ 140]					
Mass	g [oz.]	130 [4.59]	420 [14.8]		960 [33.9]	880 [31.0]	
Body material		Zinc die-casting	Aluminum die-casting				

Order Codes

□ — F11

Model

KSC22 KSC41

KSC21 KSC6

KSC31 KSC8

Inner Construction and Major Parts

● KSC22-F11

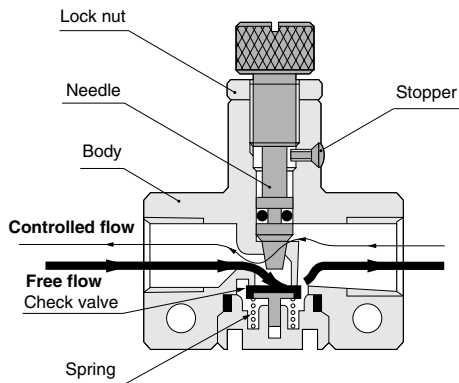

● KSC21-F11

● KSC31-F11

● KSC41-F11

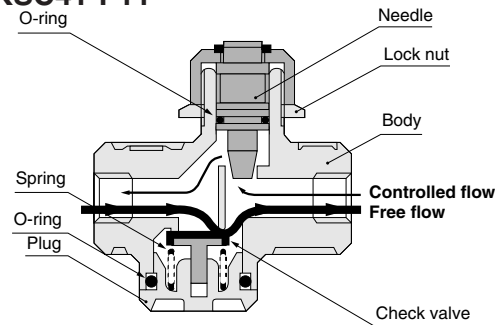

● KSC6-F11

● KSC8-F11

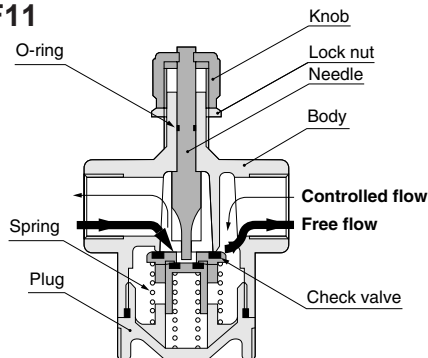

Note: In **KSC6** and **KSC8**, turning the knob clockwise increases the controlled flow rate, while turning the knob counterclockwise reduces it.
(For all other models, this is reversed.)

Dimensions (mm)

● KSC22-F11

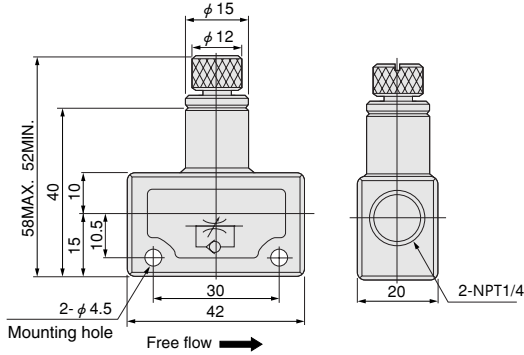

● KSC21-F11 ● KSC31-F11 ● KSC41-F11

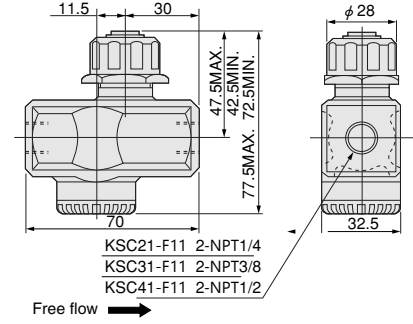

● KSC6-F11

● KSC8-F11

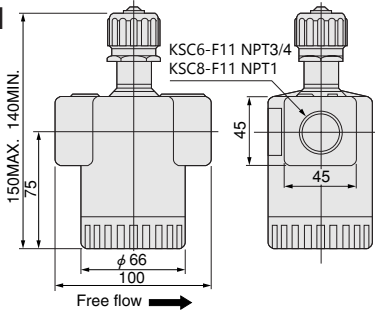

Flow Rate Characteristics

● KSC22-F11

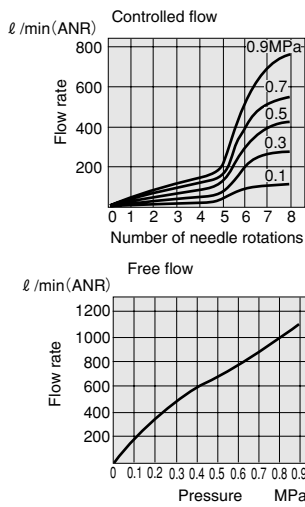

● KSC21-F11

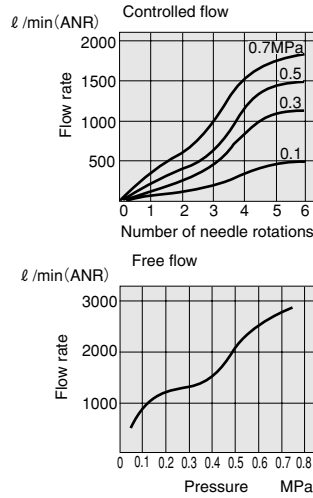

● KSC31-F11

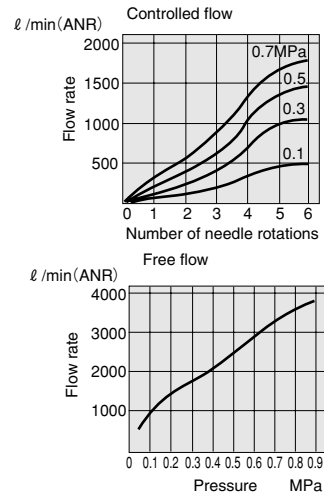

● KSC41-F11

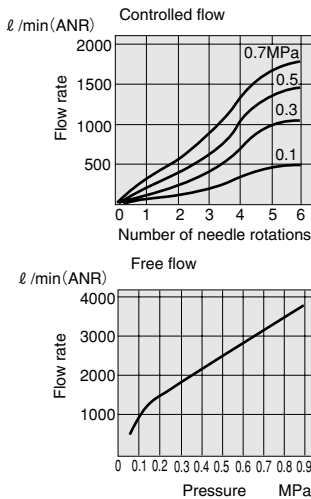

● KSC6-F11

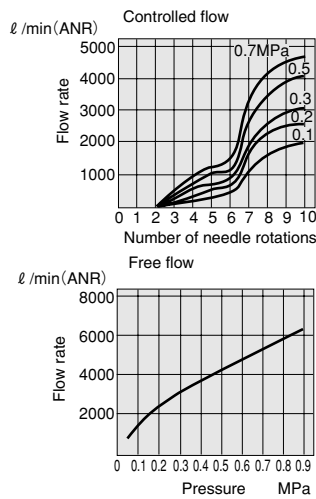



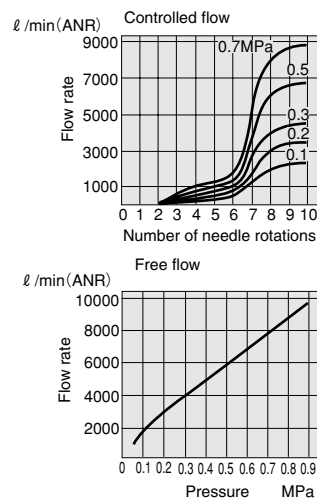

● KSC8-F11



1MPa = 145psi.
1 l/min = 0.0353ft³/min.

Before selecting and using the product, please read all the Safety Precautions carefully to ensure proper product use. The Safety Precautions shown below are to help you use the product safely and correctly, and to prevent injury or damage to you, other people, and assets beforehand. Follow the Safety Precautions for: ISO4414 (Pneumatic fluid power—Recommendations for the application of equipment to transmission and control systems), JIS B 8370 (Pneumatic system regulations)

The directions are ranked according to degree of potential danger or damage: “DANGER!”, “WARNING!”, “CAUTION!”, and “ATTENTION!”

 DANGER	Expresses situations that can be clearly predicted as dangerous. If the noted danger is not avoided, it could result in death or serious injury. It could also result in damage or destruction of assets.
 WARNING	Expresses situations that, while not immediately dangerous, could become dangerous. If the noted danger is not avoided, it could result in death or serious injury. It could also result in damage or destruction of assets.
 CAUTION	Expresses situations that, while not immediately dangerous, could become dangerous. If the noted danger is not avoided, it could result in light or semi-serious injury. It could also result in damage or destruction of assets.
 ATTENTION	While there is little chance of injury, this content refers to points that should be observed for appropriate use of the product.

- This product was designed and manufactured as parts for use in General Industrial Machinery.
- In the selection and handling of the equipment, the system designer or other person with fully adequate knowledge and experience should always read the Safety Precautions, Catalog, Owner’s Manual and other literature before commencing operation. Making mistakes in handling is dangerous.
- After reading the Owner’s Manual, Catalog, etc., always place them where they can be easily available for reference to users of this product.
- If transferring or lending the product to another person, always attach the Owner’s Manual, Catalog, etc., to the product where they are easily visible, to ensure that the new user can use the product safely and properly.
- The danger, warning, and caution items listed under these “Safety Precautions” do not cover all possible cases. Read the Catalog and Owner’s Manual carefully, and always keep safety first.

 **DANGER**

- Do not use the product for the purposes listed below:
 1. Medical equipment related to maintenance or management of human lives or bodies.
 2. Mechanical devices or equipment designed for the purpose of moving or transporting people.
 3. Critical safety components in mechanical devices.
 This product has not been planned or designed for purposes that require advanced stages of safety. It could cause injury to human life.
- Do not use the product in locations with or near dangerous substances such as flammable or ignitable substances. This product is not explosion-proof. It could ignite or burst into flames.
- When mounting the product and workpiece, always firmly support and secure them in place. Dropping or falling the product or improper operation could result in injury.
- Persons who use a pacemaker, etc., should keep a distance of at least 1 meter [3.28ft.] away from the product. There is a possibility that the pacemaker will malfunction due to the strong magnet built into the product.
- Never attempt to remodel the product. It could result in abnormal operation leading to injury, electric shock, fire, etc.
- Never attempt inappropriate disassembly, or assembly of the product relating to its basic inner construction, or to its performance or functions. It could result in injury, electric shock, fire, etc.
- Do not splash water on the product. Spraying it with water, washing it, or using it underwater could result in malfunction of the product leading to injury, electric shock, fire, etc.
- While the product is in operation, avoid touching it with your hands or otherwise approaching too close. In addition, do not make any adjustments to the interior or to the attached mechanisms (manual override, disconnection or connection of wiring connectors, adjustment of pressure switches, or disconnection of piping tubes or plugs, positioning of mounting products). Improper handling of the product could cause it to fall or operate abnormally, which could result in injury.

 **WARNING**

- Do not use the product in excess of its specification range. Such use could result in product breakdowns, function stop, damage, or drastically reduce the operating life.
- Before supplying air to the device and before starting operation, always conduct a safety check of the area of machine operation. Unintentional supply of air or electricity could possibly result in electric shock, or in injury caused by contact with moving parts.
- Do not touch the terminals and the miscellaneous switches, etc., while the device is powered on. There is a possibility of electric shock and abnormal operation.
- Do not throw the product into fire. The product could explode and/or release toxic gases.
- Do not sit on the product, place your foot on it, or place other objects on it. Accidents such as falling could result in injury. Dropping or toppling the product may result in injury, or it might also damage or break it, resulting in abnormal or erratic operation, runaway, etc.
- When conducting any kind of operation for the product, such as maintenance, inspection, repair, or replacement, always turn off the air supply completely and confirm that residual pressure inside the product or in piping connected to the product is zero before proceeding. In particular, be aware that residual air will still be in the air compressor or vacuum pump or air storage tank. The actuator could abruptly move if residual air pressure remains inside the piping, causing injury.
- In preparation for equipment shutdowns due to emergency stops, power blackouts, or other system problems, prepare safety circuit and equipment designs that prevent the occurrence of equipment damage or personal injury.
- Always release the lock on the locking type manual override before commencing normal operations. An unreleased lock could result in incorrect operation.
- Always shut OFF the power before wiring operations. Wiring with the power ON could result in electrical shocks.
- Always apply the stipulated amount of voltage to the solenoids. Applying the wrong voltage could result in failure to perform the intended function, and could damage or burn the product itself.
- Avoid scratching the cords for the sensor switch lead wires, etc. Letting the cords be subject to scratching, excessive bending, pulling, rolling up, or being placed under heavy objects or squeezed between two objects, may result in current leaks or defective continuity that lead

CAUTION

For Fluoresin Products, always read the Safety Precautions on p.819 and 866 carefully before use.

to fire, electric shock, or abnormal operation.

- Do not pull out or plug in the connectors while the power is ON. Also, do not put unnecessary stress on the connector. It could result in erratic equipment operation that could lead to personal injury, equipment breakdown, or electrical shock, etc.
- Always check the Catalog to ensure that the product wiring and piping is done correctly. Errors in wiring and piping could lead to abnormal operation of the actuators, etc.
- When mounting a solenoid valve or electro-pneumatic transducing regulator inside a control panel, or when supplying electrical power to such units over long periods of time, take heat radiation measures to ensure that temperatures surrounding the solenoid valve or electro-pneumatic transducing regulator remain within the specified ambient temperature range. If planning long periods of continuous energizing, consult us.
- In low frequency use (more than 30 days between uses), there is a possibility that contacting parts may have stuck together, resulting in equipment operation delays or sudden movements that could lead to personal injury. Run a test operation at a minimum operations frequency of 30 days between tests to confirm that movement is normal.
- Do not locate solenoid valves, electro-pneumatic transducing regulators, or the wiring for controlling such units near power lines carrying large electrical currents, or in areas subject to the generation of powerful magnetic fields or electrical surges. Such location could result in unintentional operations.
- Surge voltages and electromagnetic pulses could occur when solenoid valves and electro-pneumatic transducing regulators are being switched OFF, which could have an effect on the operations of surrounding equipment. Either use solenoids with surge suppression, or take protective measures against surges and electromagnetic pulses on electrical circuits.
- Do not use the product where ozone may be generated, such as near ocean beaches or other places subject to direct sunlight or mercury lamps. Ozone can cause rubber parts to deteriorate, which can lead to degraded performance and functions, or to equipment stoppages. (Excludes items where measures against ozone have been taken.)
- Do not use any media other than shown on the specifications. Use of non-specified media could lead to functional shutdown after a short period, to sudden performance drops, or to shorter operating life.
- In initial operations after the equipment has been idle for 48 hours or more, or has been in storage, there is a possibility that contacting parts may have stuck together, resulting in equipment operation delays or sudden movements. For these initial operations, always run a test operation before use to check that operating performance is normal.
- After wiring operations, always check to ensure that no wiring connection errors exist before turning ON the power.

CAUTION

- Do not use the product in locations that are subject to direct sunlight (ultraviolet rays), dust, salt, iron powder, high temperature, high humidity, or in the ambient atmospheres that include organic solvents, phosphate ester type hydraulic oil, sulphur dioxide, chlorine gas, acids, etc. It could lead to an early shutdown of some functions or a sudden degradation of performance, and result in a reduced operating life. For the materials used, see Major Parts and Materials.
- When installing the product, leave room for adequate working space around it. Failure to ensure adequate working space will make it more difficult to conduct daily inspections or maintenance, which could eventually lead to system shutdown or damage to the product.
- For mounting or transport of heavy products, use a lift, supporting tool, or several people, to provide firm support, and proceed with due caution to ensure personal safety.
- Always post an "operations in progress" sign for installations, adjustments, or other operations, to avoid unintentional supplying of air, electrical power, etc. Such accidental supplies may cause electric shock or sudden activation of the product that could result in physical injury.
- Do not bring floppy disks or magnetic media, etc., within 1 meter [3.28ft.] of the energized valves or electro-pneumatic transducing regulators. There is the possibility that the data on the floppy disks will be destroyed due to the magnetism of the magnet.
- Depending on the product, generation of leakage current on a control circuit could result in unintentional equipment motion. Take measures to ensure that the amount of current leaking into the control circuit does not exceed the leakage current limits allowed in the product specifications.

- For lubrication of sliding areas, use the specified lubricants. Use of the wrong lubricant could result in alteration or deterioration of the operating material's physical properties, or in degradation of its performance.
- Do not block the product's breathing holes. This will result in pressure changes due to changes in volume during operation. Blocking the breathing holes destroys the pressure balance, and could cause failure of the intended operation, equipment damage, or personal injury.
- The pressure used in vacuum equipment is vacuum (negative) pressure. Be careful to prevent positive pressure from intruding, which could cause damage to vacuum gauges and vacuum pumps. Moreover, supply of pressure greater than 0.2MPa [29psi.] for **VR100**, or 0.5MPa [73psi.] for **VR200** and **NVRA200**, could result in damage to the product.
- The properties of the lubrication oil can change if using in dry air where dew point temperature is lower than -20°C [-4°F]. It could result in degraded performance or in functional shutdown.

ATTENTION

- When considering the possibility of using this product in situations or environments not specifically noted in the Catalog or Owner's Manual, or in applications where safety is an important requirement such as in an airplane facility, combustion equipment, leisure equipment, safety equipment, and other places where human life or assets may be greatly affected, take adequate safety precautions such as an application with enough margins for ratings and performance or fail-safe measure. Be sure to consult us about such applications.
- Always check the catalog and other reference materials for product wiring and plumbing setup.
- Use a protective cover, etc., to ensure that human bodies do not come into direct contact with the operating portion of mechanical devices, etc.
- Do not control in a way that would cause workpieces to fall during power failure. Take control measures so that they prevent the table or workpieces, etc., from falling during power failure or emergency stop of the mechanical devices.
- Install a muffler, etc., on the exhaust port. It is effective in reducing exhaust noise.
- After adjusting the pressure, lock the pressure regulating knob.
- When handling the product, wear protective gloves, safety glasses, safety shoes, etc., to keep safety.
- When the product can no longer be used, or is no longer necessary, dispose of it appropriately as industrial waste.
- Pneumatic equipment can exhibit degraded performance and function over its operating life. Always conduct daily inspections of the pneumatic equipment, and confirm that all requisite system functions are satisfied, to prevent accidents from happening.
- For inquiries about the product, contact your nearest Koganei sales office or Koganei overseas department. The address and telephone number is shown on the back cover of this catalog.

OTHERS

- Always observe the following items.
 1. When using this product in pneumatic systems, always use genuine KOGANEI parts or compatible parts (recommended parts). When conducting maintenance and repairs, always use genuine KOGANEI parts or compatible parts (recommended parts). Always observe the required methods.
 2. Do not attempt inappropriate disassembly or assembly of the product relating to basic configurations, or its performance or functions.

Koganei cannot be responsible if these items are not properly observed.